



ALWAYS
THE BEST
**FLEXIBLE
SAFETY
BARRIERS**





PRESENTS NEW MATERIALS



CONTENTS

01	Rack Protection	page 08	10	Column Protection	page 68
02	Bollard	page 20	11	Door Frame Protections	page 76
03	Guard Rails	page 24	12	Loading Bay Protection	page 82
04	Cold Line	page 30	13	Wheel Stop	page 86
05	Pedestrian Safety Barriers	page 38	14	Cable Cover	page 90
06	Pin	page 44	15	Corner Protection	page 92
07	Gates	page 48	16	Kerb	page 94
08	Link	page 54	17	Wall Protection	page 98
09	BFlex	page 62			



mpm
FLEXIBLE PROTECTIONS
WAREHOUSE

OFFICE

mpm
FLEXIBLE PROTECTIONS

mpm

mpm

mpm

mpm

mpm

mpm

mpm

mpm

mpm

mpm

mpm

SAFETY ZONE

EXIT

mpm

OUR MATERIALS

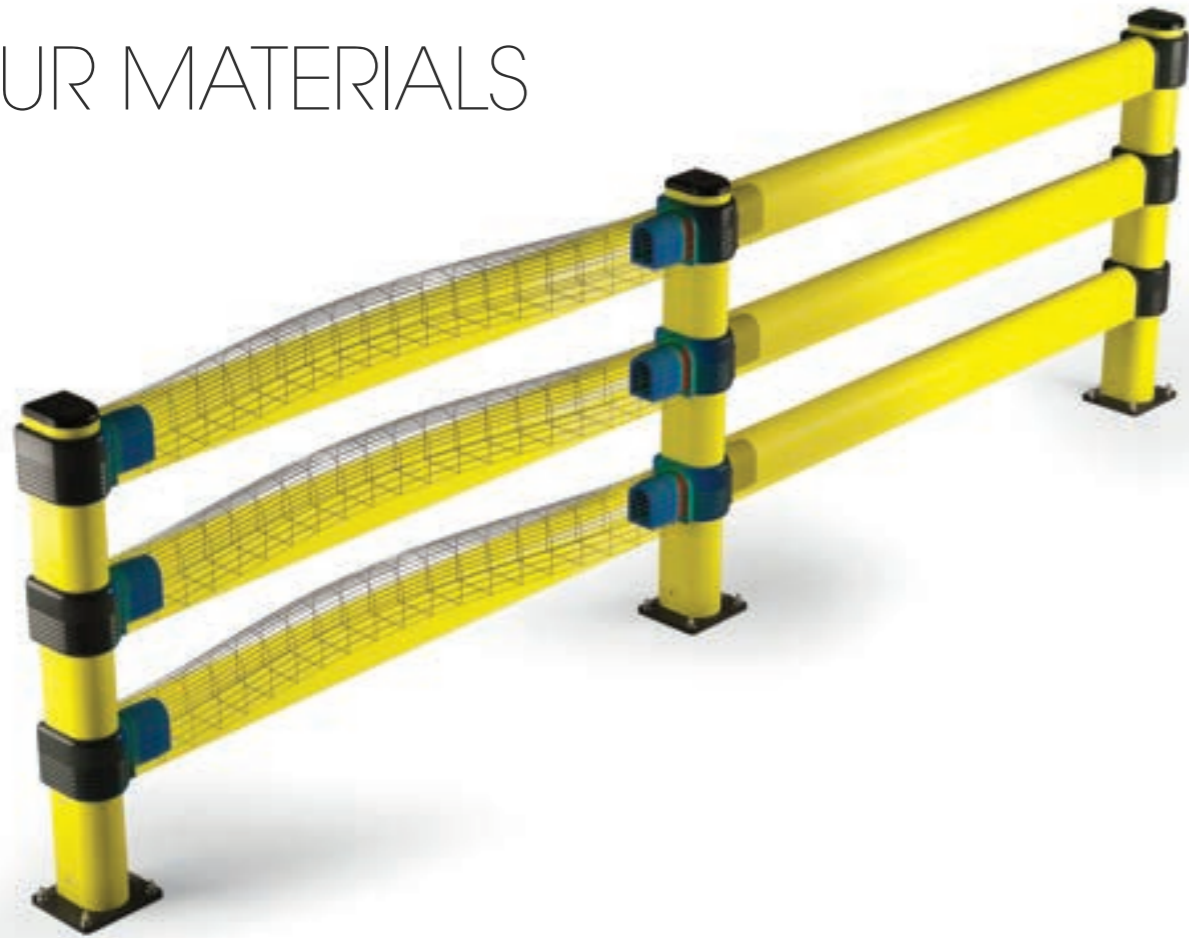

RESISTANT OVER TIME

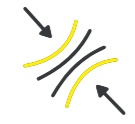

HIGH ELASTICITY



COMPLIANT WITH THE DIRECTIVE UE 2015/863 (ROHS)



100% RICYCLABLE



SELF EXTINGUISHING V0

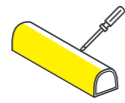

SCRATCHPROOF MATERIAL



HIGH VISIBILITY AND NO PAINTING REQUIRED



EASY TO CLEAN



ROT-PROOF AND NORMALLY MILDEW-PROOF MATERIAL



NO TOXIC



RESISTANT TO CHEMICALS OIL AND FUELS



RESISTANT TO HUMIDITY AND SALINITY



TEMPERATURE RANGE: -30° + 50° C

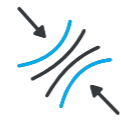

HIGH ELASTICITY



COMPLIANT WITH THE DIRECTIVE UE 2015/863 (ROHS)



100% RICYCLABLE



HB FLAMMABILITY RATING ACCORDING TO UL 94



SUITABLE FOR FOOD CONTACT



HIGH VISIBILITY AND NO PAINTING REQUIRED



RESISTANT TO CHEMICALS OIL AND FUELS



ROT-PROOF AND NORMALLY MILDEW-PROOF MATERIAL



NO TOXIC



RESISTANT TO HUMIDITY AND SALINITY

FIRE CERTIFICATION FOR MPM REFLEX

OUR POLYMER CONFIRMS THE V0 SELF-EXTINGUISHING CLASS

MPM barriers are classified V0, according to international UL94 standard. The protections in Reflex technopolymer:

- Are low fire risk;
- Are self-extinguishing;
- Don't spread the flame and stop burning within few seconds.

The installation of our barriers lowers fire risk, in order to measure the size of the fire extinguishing system, compared to other barriers made of alternative polymers - not classified as V0.

Le barriere MPM sono classificate V0, secondo lo standard internazionale UL94. Le protezioni in tecnopolimero Reflex:

- Hanno un basso carico d'incendio;
- Sono autoestinguenti;
- Non propagano la fiamma e smettono di bruciare entro pochi secondi.

L'installazione delle nostre barriere riduce il carico d'incendio utilizzato ai fini del calcolo del dimensionamento del sistema antincendio, rispetto ad altre barriere in polimeri alternativi - non classificati V0.

Les barrières MPM sont classées V0, selon la norme internationale UL94. Les protecteurs en technopolymère Reflex:

- Ils ont une faible charge d'incendie;
- Ils sont auto-extinguibles;
- Ils ne propagent pas la flamme et cessent de brûler en quelques secondes.

La présence de nos barrières réduit la charge d'incendie utilisée pour le calcul du dimensionnement du système d'extinction d'incendie, par rapport à d'autres barrières en polymères alternatifs - non classées V0.

Las barreras MPM están clasificadas como V0, según la norma internacional UL94. Las protecciones de tecnopolímero Reflex:

- Tienen una baja carga de fuego;
- Son autoextinguibles;
- No propagan la llama y dejan de arder en unos segundos.

La instalación de nuestras barreras reduce la carga de fuego utilizada para el cálculo del dimensionamiento del sistema de protección contra incendios, en comparación con otras barreras de polímero alternativas, no clasificadas como V0.



IS FIRE RESISTANT
CLASS V-0

RESEARCH AND DEVELOPMENT NEVER STOP!

AVAILABLE FOR:
LM / PED 150 /
TOWER

ORANGE LINE



HIGHER
VISIBILITY
FOR A GREATER
SAFETY!

CLIP 90

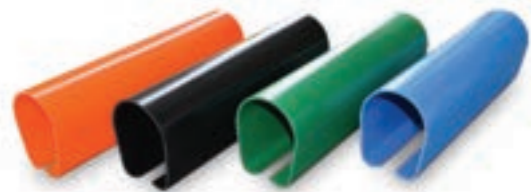

CUSTOMIZE
YOUR BARRIER

EASY TO
INSTALL

MORE
VISIBILITY



CUT THE RAIL AND DRILL IT WITH

GENIUS 
THE LENGTH THAT YOU WISH



FOR PEDESTRIAN
BARRIER CORNER
RAILS



FOR PEDESTRIAN
BARRIER RAILS

WORLD'S UNIQUE SYSTEM!

YOUR CUSTOMIZED
BARRIER AND HUG TOWER



01

RACK PROTECTION OUR PROFILES FIT ALL RACKS

Full range of techno polymer profiles for protection of warehouse racks.

Gamma completa di profili in tecnopolimeri per la protezione di scaffali.

Complète gamme de profilés en tecnopolimère pour la protection d'étagères de dépôts.

Gama completa de perfiles de tecnopolímeros para las protecciones de estanterías.

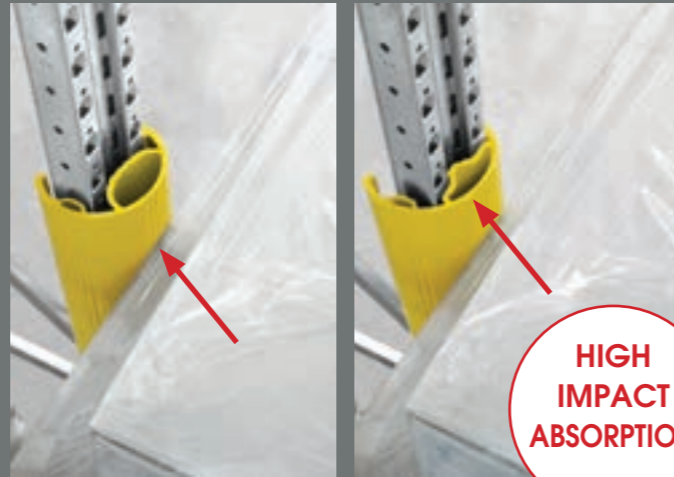

HIGH IMPACT ABSORPTION

- ▶ **One big central shock absorber** in soft material to absorb front impacts.
- ▶ **Two side shock absorbers** in soft material to absorb impact during pallet placement on the rack.
- ▶ **Tested and certified** to EN 15512
- ▶ **Reduced dimensions** to keep manoeuvring spaces clear.
- ▶ **Interlocking system** with practical click-fit tools.
- ▶ **Rigid outer cladding, scratch-resistant** and easy to clean.



RPS / RPM / RPL

EASY TO INSTALL

THE ONLY ONE WITH TRIPLE SHOCK ABSORBER



CUSTOMIZED SOLUTIONS TO FIT ALL UPRIGHTS



RPS 600

Small

Available also size 400



Packing 6 pz / box
Packing 115 pz / big parcel
Colour M



RPM 600

Medium

Available also size 400



Packing 4 pz / box
Packing 80 pz / big parcel
Colour M



RPL 600

Large

Available also size 400



Packing 2 pz / box
Packing 52 pz / big parcel
Colour M



RPL XL 600

Extra Large

Available also size 400



Packing to be defined
Colour M



RP CLICK

Packing 1 pz / box

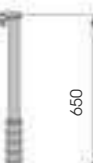

RACK CORNER

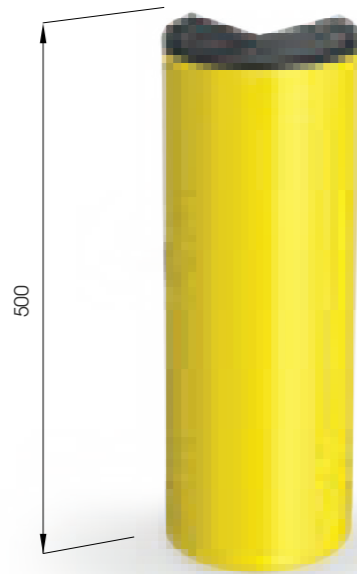

RACK CORNER

Equipped with accessories

Packing Colour **M** to be defined

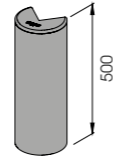

SM



M12 GALVANISED STEEL



SM 1100x400

Equipped with accessories

Length **1.100**
Packing **unpacked on pallet**
Colour **B M**

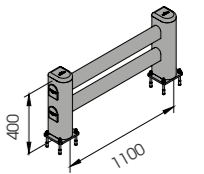

SM 1500x400 MODULAR

Equipped with accessories

Packing **unpacked on pallet**
Colour **B M**

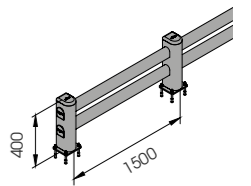

LM



DIFFERENT SIZES ON REQUEST

FAST AND EASY TO INSTALL



M12 GALVANISED STEEL



LM RACK END 1100x500 2400x500

Length 1.100 / 2.400 mm
Packing unpacked on pallet
Colour B M

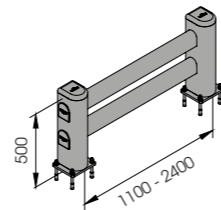

Equipped with accessories



LM 2000x500 MODULAR

Packing unpacked on pallet
Colour B M

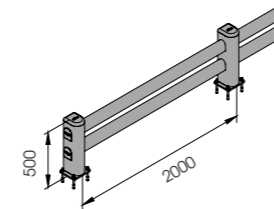

Equipped with accessories



LM/1 LINK



DIFFERENT SIZES ON REQUEST

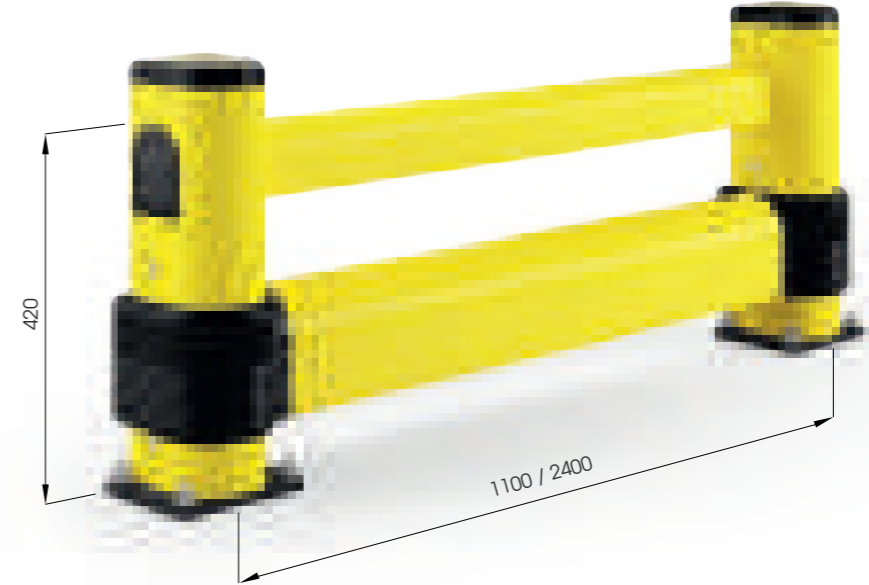

M12 GALVANISED STEEL



LM/1 LINK RACK END 1100x500 2400x500

Length 1.100 / 2.400 mm
Packing unpacked on pallet
Colour B M

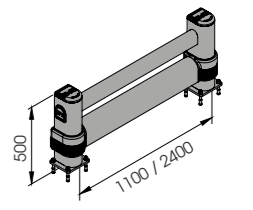

Equipped with accessories



LM / 1 LINK 2000x500 MODULAR

Packing unpacked on pallet
Colour B M

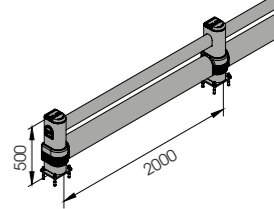

Equipped with accessories



LINK SINGLE



DIFFERENT SIZES ON REQUEST



M12 GALVANISED STEEL



LINK SINGLE RACK END
1100x500
1100x800
2400x500
2400x800

Length Packing Colour
1.100 / 2.400 mm
unpacked on pallet
B M

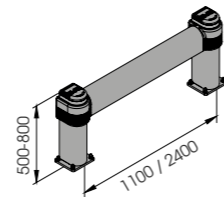

Equipped with accessories

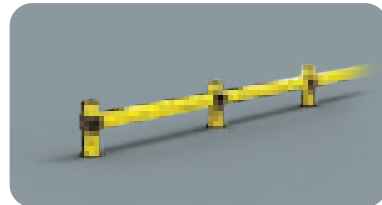

LINK SINGLE 2000x500 MODULAR
LINK SINGLE 2000x800 MODULAR

Packing Colour
unpacked on pallet
B M

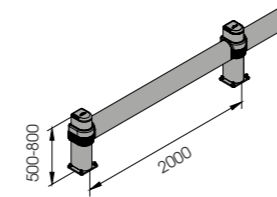

Equipped with accessories



LINK LM



DIFFERENT SIZES ON REQUEST



M12 GALVANISED STEEL



LINK LM RACK END
1100x500
1100x800
2400x500
2400x800

Length Packing Colour
1.100 / 2.400 mm
unpacked on pallet
B M

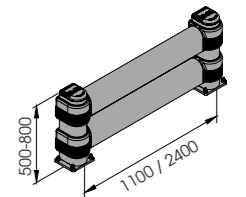

Equipped with accessories



LINK LM 2000x500 MODULAR
LINK LM 2000x800 MODULAR

Packing Colour
unpacked on pallet
B M

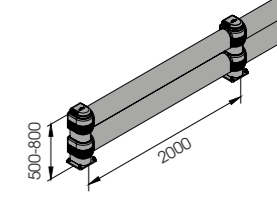

Equipped with accessories



FENCE 90



DIFFERENT SIZES ON REQUEST

FAST AND EASY TO INSTALL



M12 GALVANISED STEEL



FE 90 1100x400

Length 1.100 mm
Packing unpacked on pallet
Colour B M



Equipped with accessories



FE 90 2400x400

Length 2.400 mm
Packing unpacked on pallet
Colour B M



Equipped with accessories



FENCE 150



DIFFERENT SIZES ON REQUEST

FAST AND EASY TO INSTALL



M12 GALVANISED STEEL



FE 150 1100x550

Length 1.100 mm
Packing unpacked on pallet
Colour B M



Equipped with accessories



FE 150 2400x550

Length 2.400 mm
Packing unpacked on pallet
Colour B M



Equipped with accessories



FENCE 150 REINFORCED



DIFFERENT SIZES ON REQUEST

FAST AND EASY TO INSTALL



FE 150 REF 1100x550

Length **1.100 mm**
Packing **unpacked on pallet**
Colour **B M**



Equipped with accessories



FE 150 REF 2400x550

Length **2.400 mm**
Packing **unpacked on pallet**
Colour **B M**



Equipped with accessories

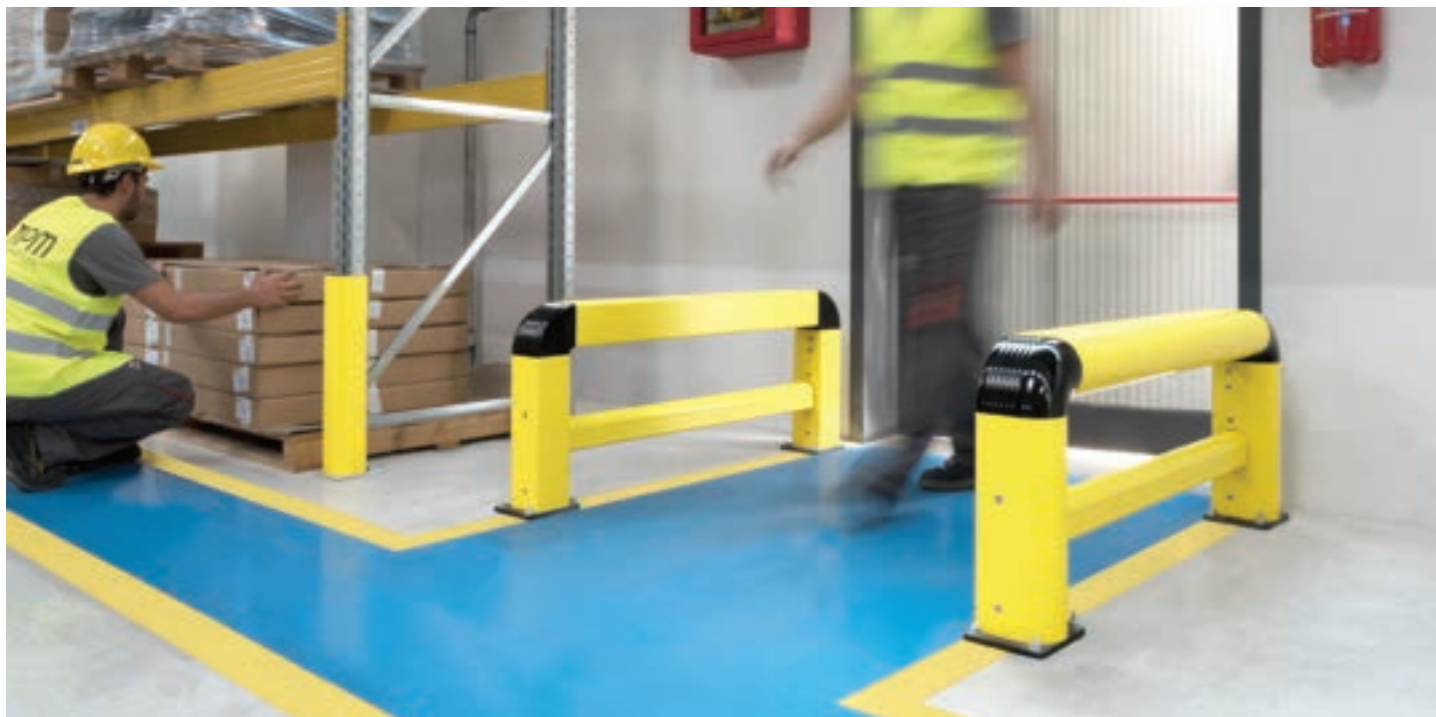

FENCE LINK



DIFFERENT SIZES ON REQUEST

FAST AND EASY TO INSTALL



FE LINK 1100x550

Length **1.100 mm**
Packing **unpacked on pallet**
Colour **B M**

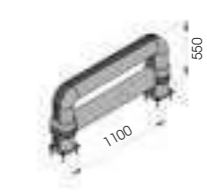

Equipped with accessories



FE LINK 2400x550

Length **2.400 mm**
Packing **unpacked on pallet**
Colour **B M**



Equipped with accessories



02

BOLLARD

Designed to protect access to gates or big doors from huge traffic or simply to mark restricted areas for pedestrians. Fully equipped with fixing accessories.

Ideato per proteggere l'accesso a cancelli o portoni dalla movimentazione di mezzi pesanti o semplicemente per impedire l'ingresso di pedoni. Provvisto di accessori di fissaggio.

Étudié pour protéger l'accès aux portes ou entrées de grand trafic ou simplement pour marquer les zones de passage piétons. Equipé avec les accessoires d'installation.

Diseñado para proteger el acceso a puertas o portones del movimiento de vehículos pesados o simplemente para evitar la entrada de peatones. Provisto de accesorios de fijación.



GRD 90



Bollard

FAST AND EASY TO INSTALL



M12 GALVANISED STEEL



GRD 90 250

Packing Colour **unpacked on pallet**
 B M

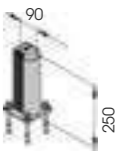

Equipped with accessories



GRD 150

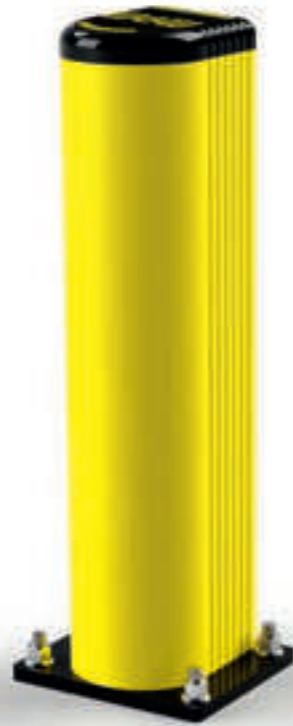

FAST AND EASY TO INSTALL



M12 GALVANISED STEEL

GRD 200



INCLUDED

FAST AND EASY TO INSTALL



S16 GALVANISED STEEL

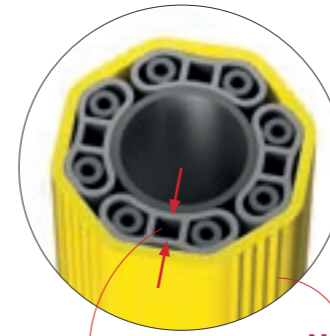

FLEXIBLE

NEW ANTISHOCK BUMPER



GRD 150 500
800
1150

Packing Colour **unpacked on pallet**
B M

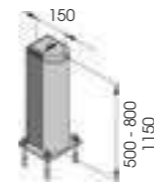

Equipped with accessories



GRD 200 1200
2000

Packing Colour **unpacked on pallet**
M

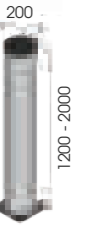

Equipped with accessories



03

GUARD
RAILS

A new bumper system specific for the protection of the walls resistant against trolleys movements. Developed by following an innovative technical design that combines speed and simplicity during installation and cleaning. Available in different lengths.

Sistema profili antiurto specifico per la protezione delle pareti dai carrelli in movimento. Progettato seguendo un innovativo disegno tecnico che coniuga rapidità e semplicità nelle fasi di installazione e pulizia. Disponibile in diverse lunghezze.

Nouveau système bumper, spécifique pour protéger les murs contre les mouvements des charriots. Étudié avec un modern dessin qui regroupe la rapidité et la facilité pendant l'installation et le nettoyage. Disponible en différents longueurs.

Sistema de perfiles anti-impacto específico para la protección de las paredes de los carros en movimiento. Diseñado según un diseño técnico innovador que une velocidad y simplicidad en las fases de instalación y limpieza. Disponible en diferentes longitudes.

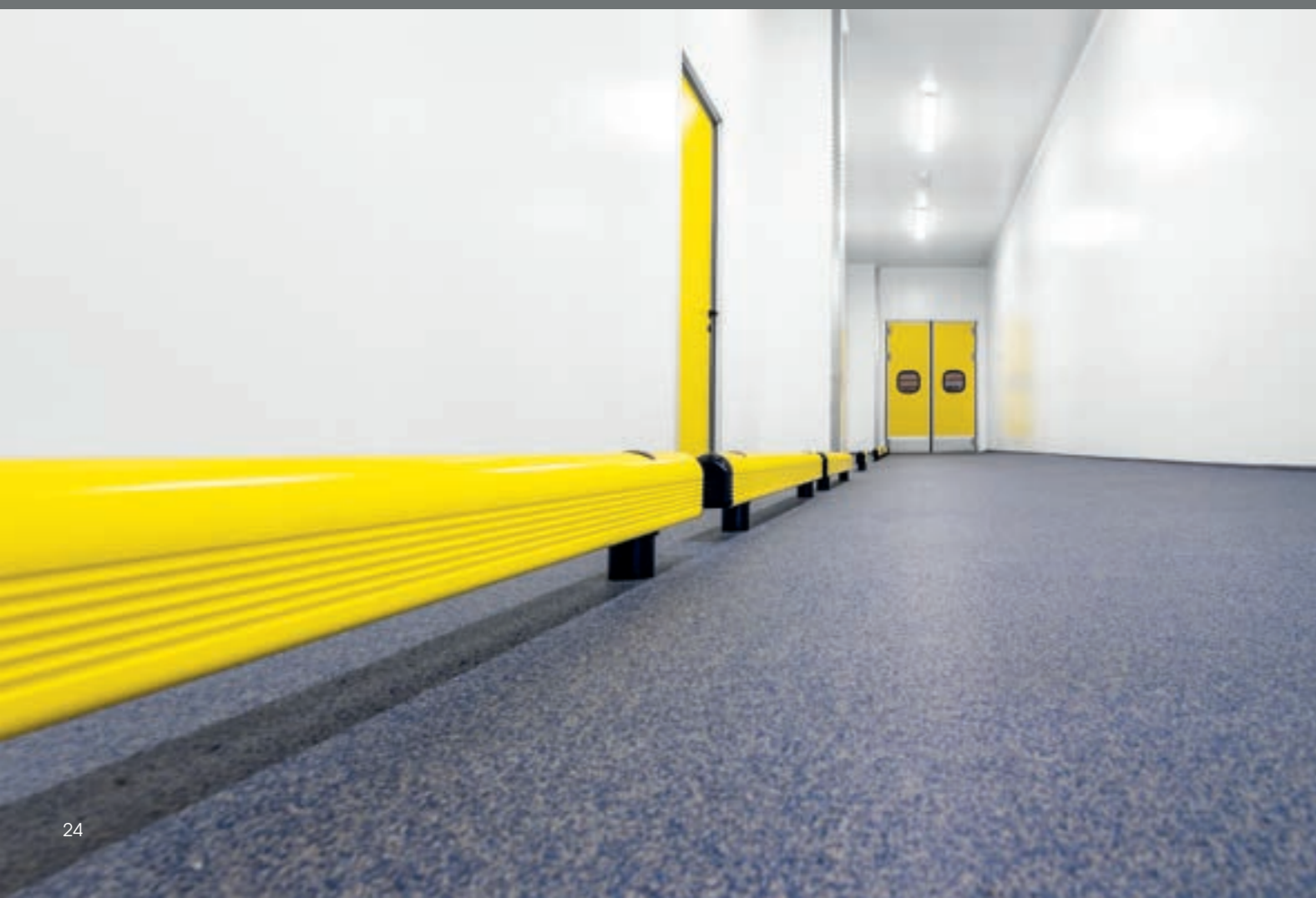

GUARD RAIL 90



QUICK
INSTALLATION
WITH
EXPANSION
SCREW



M16
GALVANISED STEEL

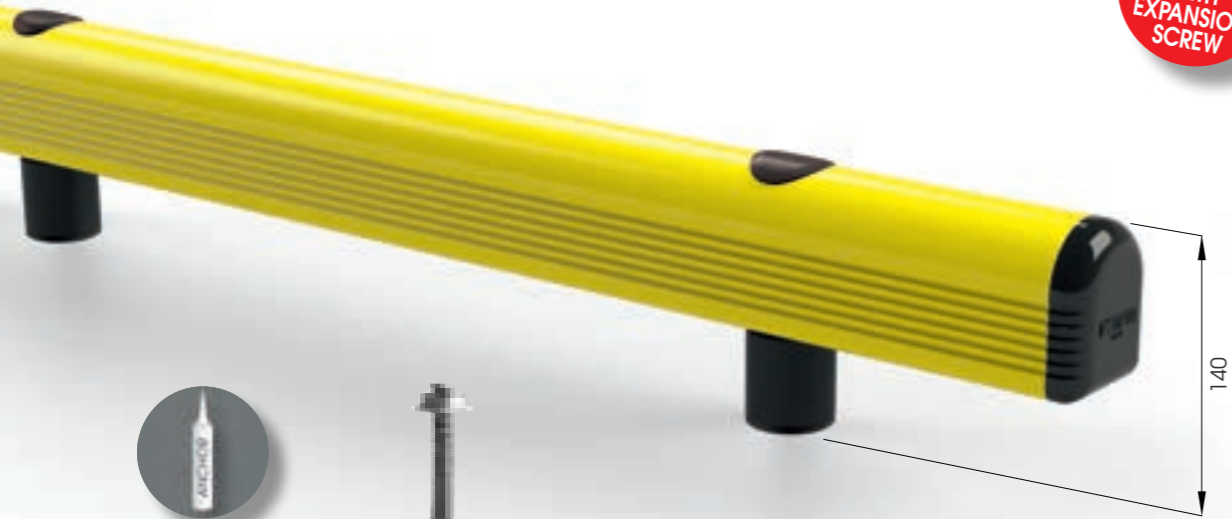

ALTERNATIVE FIXING
HIGH RESISTANCE WITH RESIN
SF16
STAINLESS STEEL



GR 90 500
750
1000
1500

Length 500 mm
Packing unpacked on pallet

Length 750 / 1000 / 1500 mm
Packing 2 pz / box

Colour B M

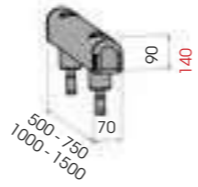

Equipped with accessories



GR 90 2000
3000
4000

Length 2.000 / 3.000 / 4.000 mm
Packing unpacked on pallet

Colour B M

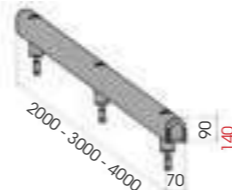

Equipped with accessories



GUARD RAIL 150



HIGH
RESISTANCE
WITH
RESIN



SF20
STAINLESS STEEL



GR 150 500
750
1000
1500

Length 500 / 750 /
1000 / 1500 mm

Packing unpacked on pallet

Colour B M

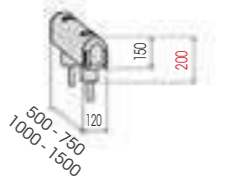

Equipped with accessories



GR 150 2000
3000
4000

Length 2.000 / 3.000 / 4.000 mm

Packing unpacked on pallet

Colour B M

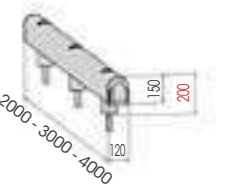

Equipped with accessories



GRIN 90

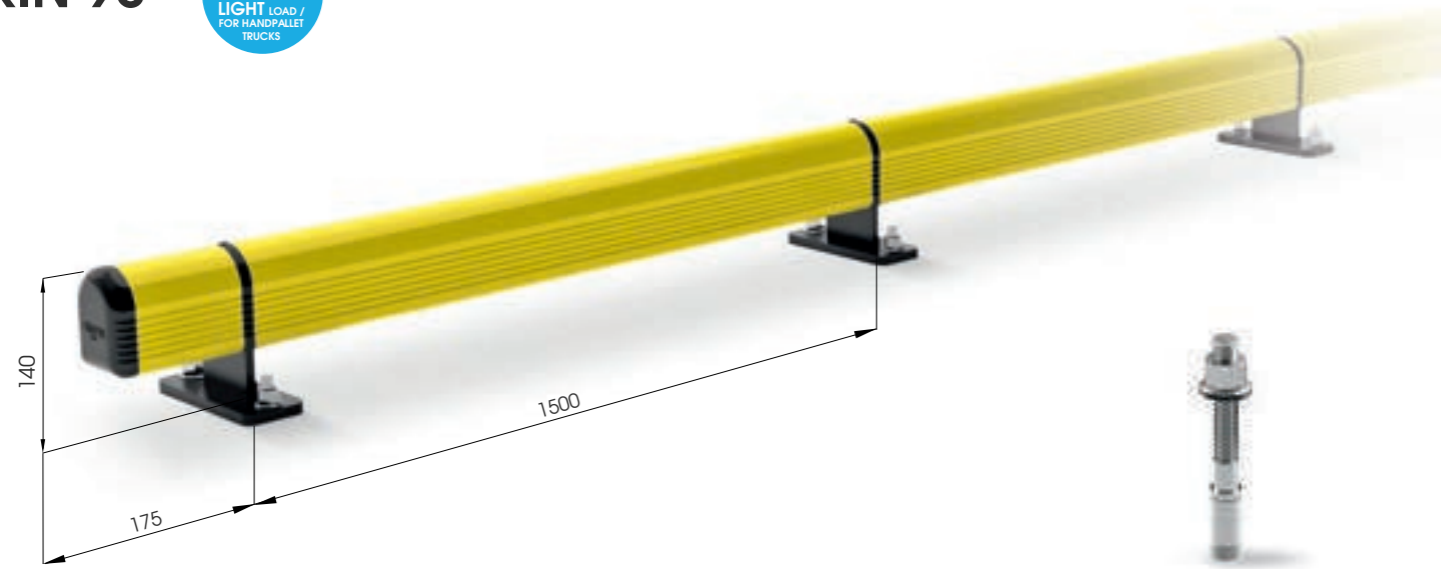

M12 GALVANISED STEEL

GRIN 150



M12 GALVANISED STEEL



GRIN 90 1500

Length **1500 mm**
Packing **to be defined**
Colour **M**



GRINCO 90

Packing **to be defined**
Colour **M**



Equipped with accessories



GRINT 90

Packing **to be defined**
Colour **M**



Equipped with accessories



GRIN 150 2000

Length **2000 mm**
Packing **to be defined**
Colour **M**



GRINCO 150

Packing **to be defined**
Colour **M**



Equipped with accessories



GRINT 150

Packing **to be defined**
Colour **M**



Equipped with accessories



04

COLD LINE

Specific solutions for the protection of areas at risk of impact, in environments with negative temperature. They are suitable to protect corners, entrances, gates, panels and cold rooms walls.

Soluzioni specifiche per la protezione di zone a rischio d'impatto in ambienti a temperatura negativa. Ideali per proteggere angoli sporgenti, accessi e portoni, pannelli e pareti di celle frigorifere.

Solutions spécifiques pour la protection des zones à risque de collision dans les environnements à température négative. Idéal pour protéger les angles, les entrées et les portes, les panneaux et les murs des chambres froides.

Soluciones específicas para proteger las zonas con riesgo de impacto en entornos de temperatura negativa. Son ideales para proteger esquinas, entradas y puertas, paneles y paredes de las cámaras frigoríficas.



FROSTEX
RESISTANT TO LOW TEMPERATURES

-30° RESISTANT TO LOW TEMPERATURES

ROD 70

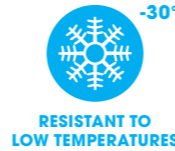

REMOVABLE
EASY TO REMOVE AND TO REPLACE



M20 GALVANISED STEEL

Fixing accessory available also in stainless steel



ROD 70 266

Drill Ø 38
Equipped with accessories

Packing Colour **1 pz / box**
M

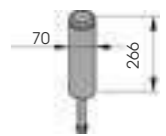

ROD 120



REMOVABLE
EASY TO REMOVE AND TO REPLACE



M30 GALVANISED STEEL

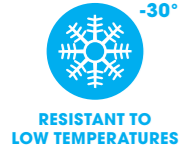

Fixing accessory available also in stainless steel



ROD 120 433
560
800

Drill \varnothing 56
Equipped with accessories

Packing 1 pz / bag
Colour **M**

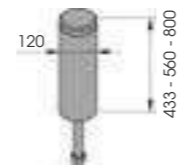

ROD FLOOR 70



QUICK INSTALLATION WITH EXPANSION SCREW



M16 GALVANISED STEEL

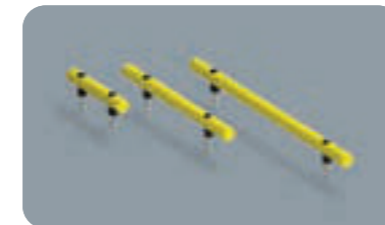

RF 70 500
1000
1500

Length 500 / 1000 / 1500 mm
Packing unpacked on pallet
Colour **M**

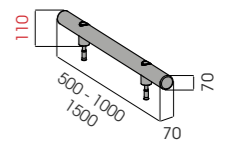

Equipped with accessories



RF 70 2000
3000

Length 2.000 / 3.000 mm
Packing unpacked on pallet
Colour **M**

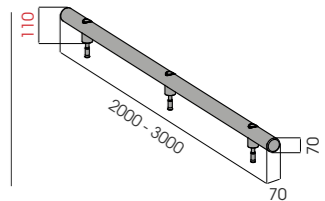

Equipped with accessories



ROD FLOOR 100



HIGH RESISTANCE WITH RESIN



SF20 STAINLESS STEEL

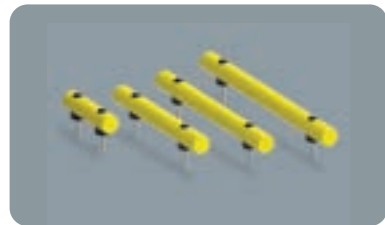
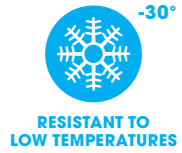

RF 100 500
1000
1500

Length 500 / 1000 / 1500 mm
Packing unpacked on pallet
Colour M

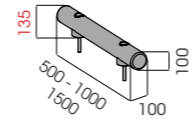

Equipped with accessories



RF 100 2000
3000

Length 2.000 / 3.000 mm
Packing unpacked on pallet
Colour M

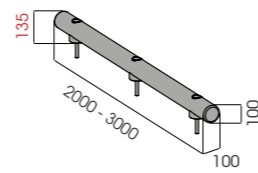

Equipped with accessories



ROD FLOOR 120



HIGH RESISTANCE WITH RESIN



SF20 STAINLESS STEEL

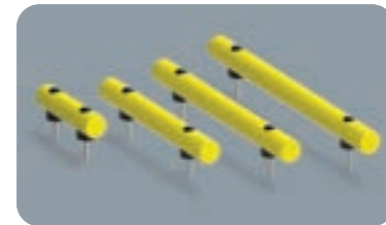
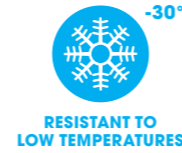

RF 120 500
1000
1100
1500

Length 500 / 1000 / 1100 / 1500 mm
Packing unpacked on pallet
Colour M

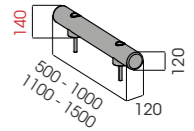

Equipped with accessories

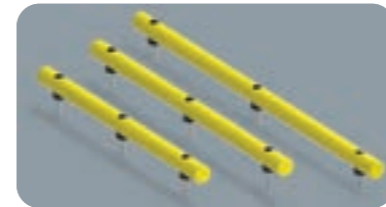

RF 120 2000
2500
3000

Length 2.000 / 2.500 / 3.000 mm
Packing unpacked on pallet
Colour M

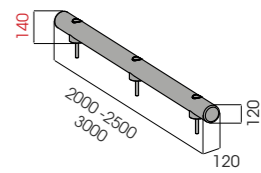

Equipped with accessories



ROD FLOOR 120 DOUBLE RACK END



SF20 x 450
STAINLESS STEEL



NO SHARP EDGES



RESISTANT TO
LOW TEMPERATURES



RF 120 DOUBLE RACK
END 1100

Length 1100 mm
Packing unpacked on pallet
Colour M

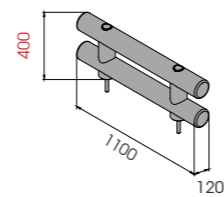

Equipped with accessories



RF 120 DOUBLE RACK
END 2500

Length 2.500 mm
Packing unpacked on pallet
Colour M

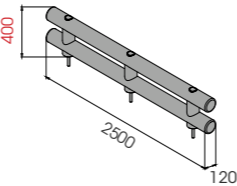

Equipped with accessories



ROD FLOOR 120 DOUBLE

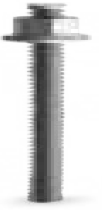

SF20 x 450
STAINLESS STEEL

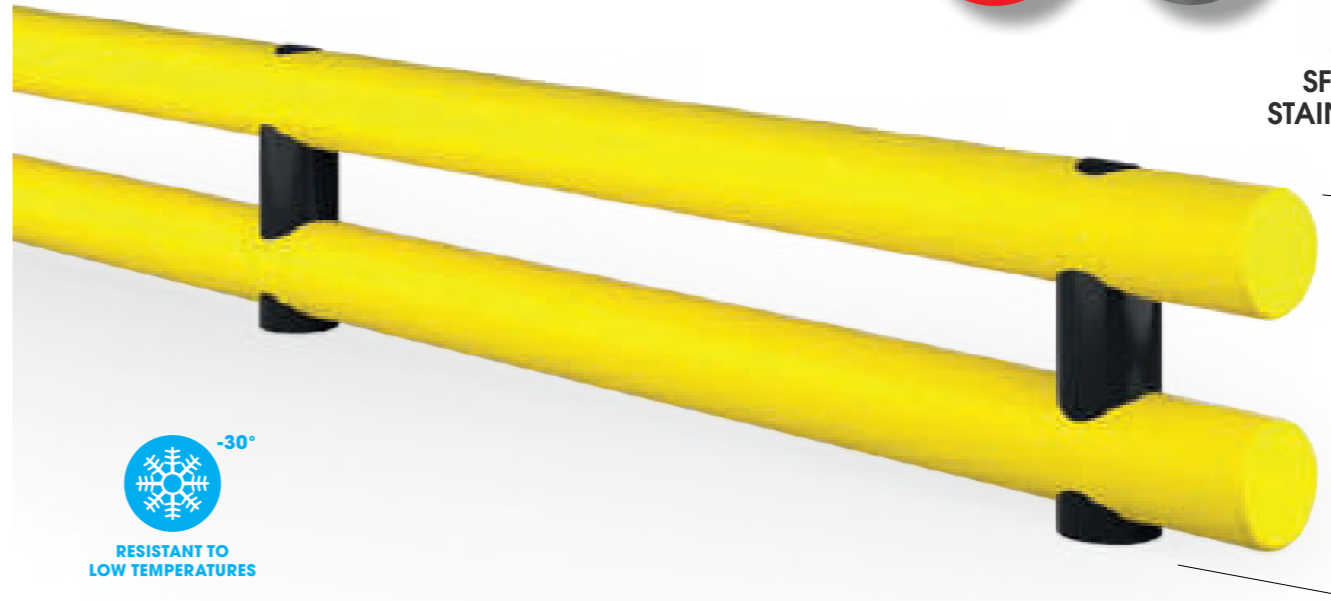

RESISTANT TO
LOW TEMPERATURES

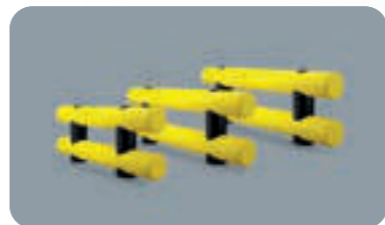

RF 120 DOUBLE 500
1000
1500

Length 500 / 1000 / 1500 mm
Packing unpacked on pallet
Colour M

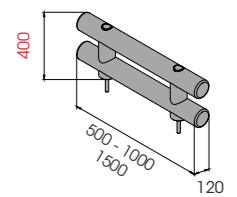

Equipped with accessories



RF 120 DOUBLE 2000
3000

Length 2.000 / 3.000 mm
Packing unpacked on pallet
Colour M

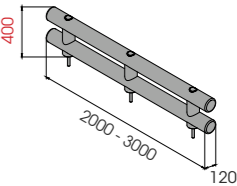

Equipped with accessories



05

PEDESTRIAN SAFETY BARRIERS

A new protection system specific for the protection of pedestrians and resistant to trolleys movements with different load types. Developed by following an innovative technical design that combines speed and simplicity during installation and cleaning. Available in different lengths.

Sistema di profili antiurto specifico per la protezione delle aree pedonali dai carrelli in movimento con diverse portate di carico. Progettato seguendo un innovativo disegno tecnico che coniuga rapidità e semplicità nelle fasi di installazione e pulizia. Disponibile in diverse lunghezze.

Nouveau système bumper, spécifique pour protéger les zones piétonnes contre les mouvements des charriots. Étudié avec un modern dessin qui regroupe la rapidité et la facilité pendant l'installation et le nettoyage. Disponible en différents longueurs.

Sistema específico de perfiles antichoque para la protección de zonas peatonales de carros en movimiento con diferentes capacidades de carga. Diseñado según un diseño técnico innovador que une velocidad y simplicidad en las fases de instalación y limpieza. Disponible en diferentes longitudes.



HAND RAIL 90



M12 GALVANISED STEEL



HR 90 1500x1150 MODULAR

Packing Colour **unpacked on pallet**
M

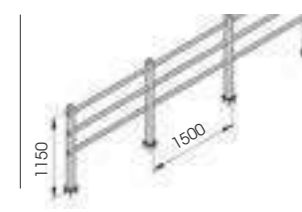

Equipped with accessories

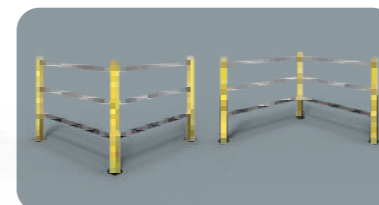

HR 90 1500x1150 CORNER

Packing Colour **unpacked on pallet**
M

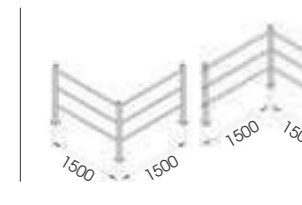

Equipped with accessories



PEDESTRIAN 90



FAST AND EASY TO INSTALL



M12 GALVANISED STEEL

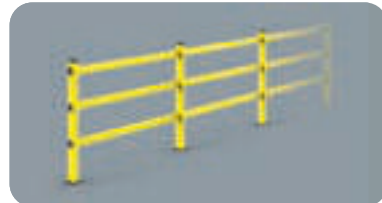

PED 90 1500x1150 MODULAR

Packing Colour **unpacked on pallet**
B M



Equipped with accessories



PED 90 1500x1150 CORNER

Packing Colour **unpacked on pallet**
B M

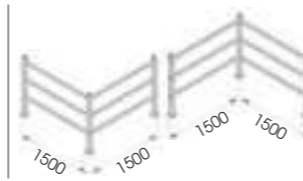

Equipped with accessories



PEDESTRIAN 150



FAST AND EASY TO INSTALL



M12 GALVANISED STEEL



PED 150 2000x1150 MODULAR

Packing Colour **unpacked on pallet**
B M

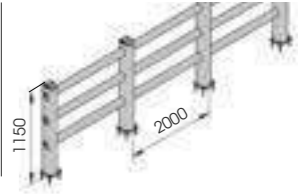

Equipped with accessories

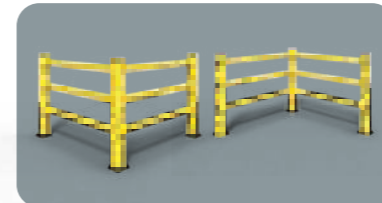

PED 150 2000x1150 CORNER

Packing Colour **unpacked on pallet**
B M

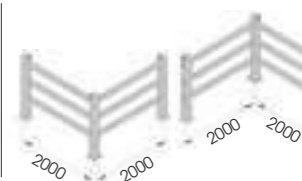

Equipped with accessories

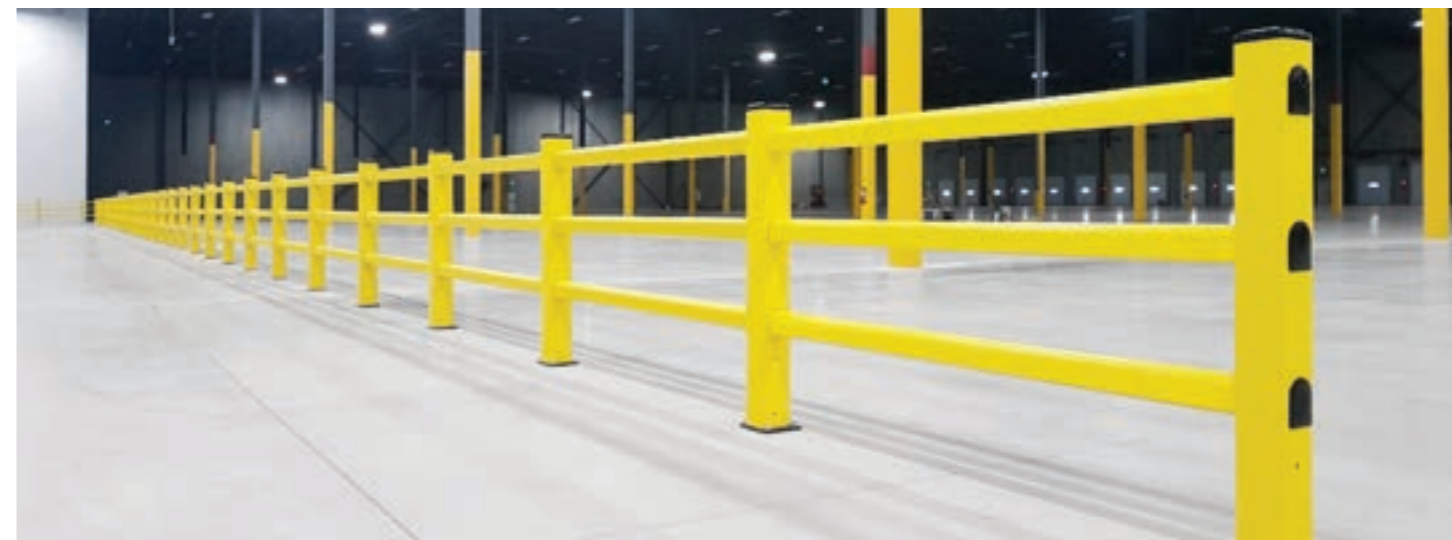

PEDESTRIAN 90 REINFORCED

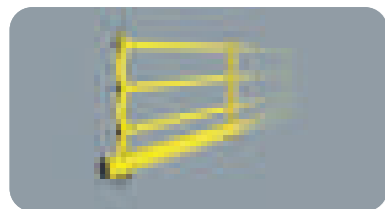

PED 90 REF MODULAR

Packing Colour **unpacked on pallet**
B M



Equipped with accessories



PEDESTRIAN 150 LINK



PED 150 LINK

External Corners available

Packing Colour **unpacked on pallet**
B M

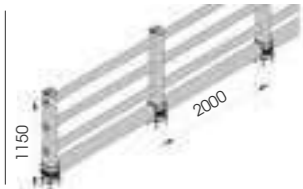

Equipped with accessories



06

PIN

New pin barrier system, developed with an innovative beam connection mechanism and a new special soft and shock-absorbing gasket. The barrier is even more flexible and resistant to impacts.

Nuovo sistema di barriere pin, progettato con un innovativo meccanismo di connessione dei traversi e una speciale guarnizione morbida ammortizzante. La barriera è ancora più resistente e flessibile all'impatto.

Nouveau système de barrière pin, conçu avec un mécanisme de connexion des traverses innovant et un joint souple spécial amortissant. La barrière est encore plus résistante et flexible aux chocs.

Nuevo sistema de barrera PIN, diseñado con un innovador mecanismo de conexión entre las barras horizontales y con una especial junta de material blando que actúa como un amortiguador. La barrera es aún más resistente y flexible al impacto.

THE BEST HIGH-PERFORMANCE BARRIER SYSTEM

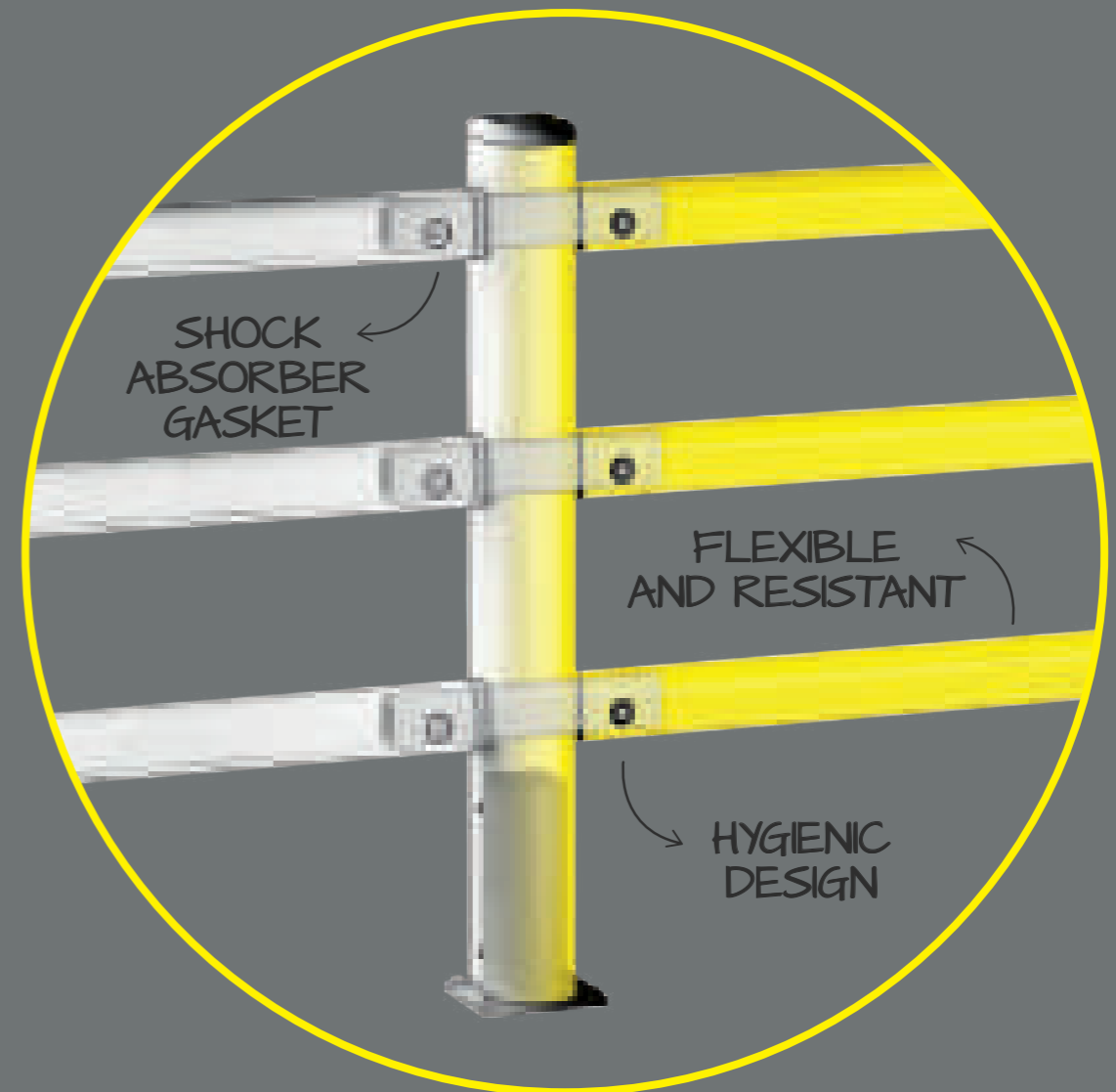

PED 150 PIN



FAST AND EASY TO INSTALL

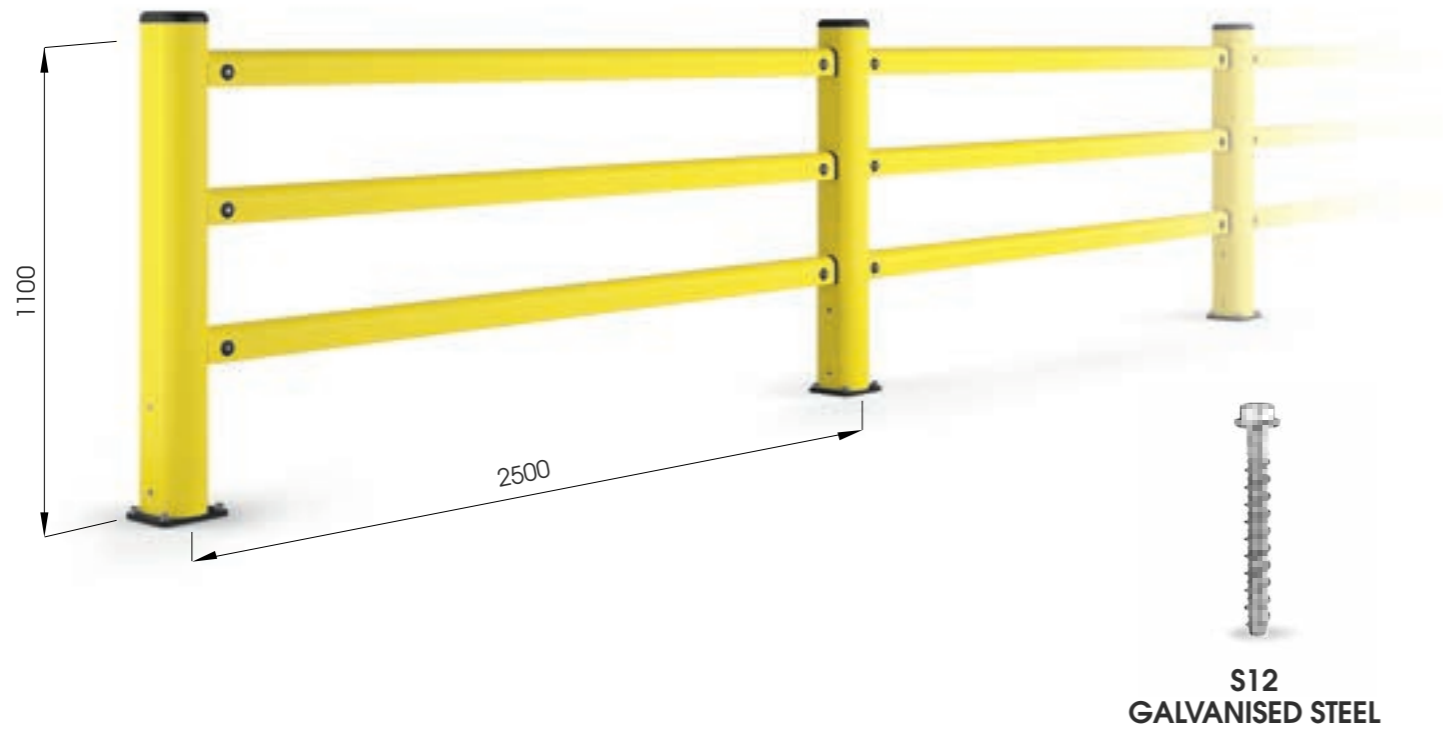

S12 GALVANISED STEEL

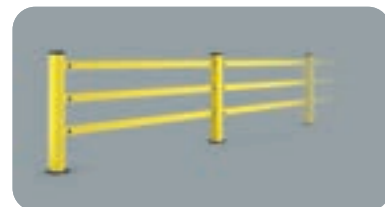

PED 150 PIN
2500x1150

Packing Colour **unpacked on pallet**
B M



Equipped with accessories



PED 200 PIN



FAST AND EASY TO INSTALL

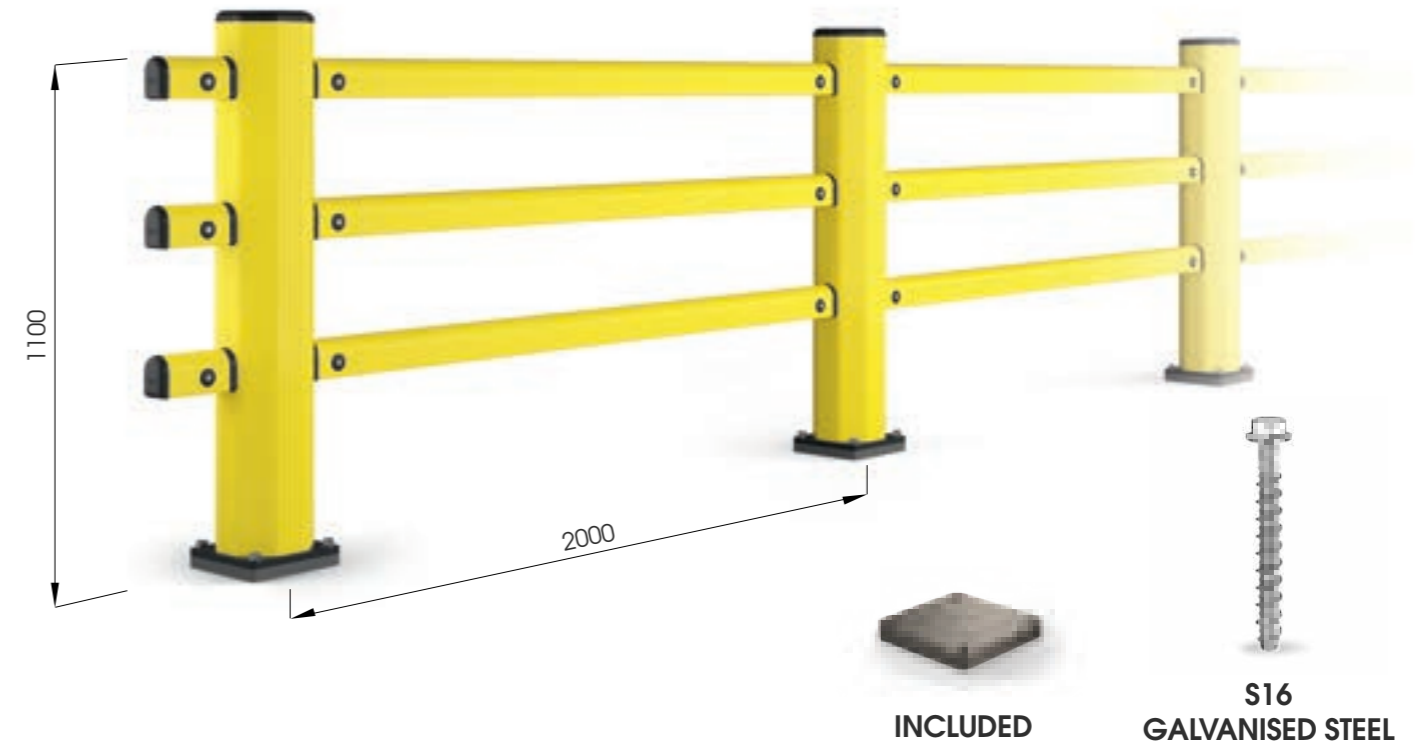

S16 GALVANISED STEEL

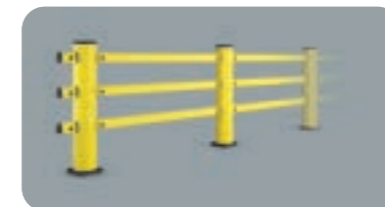

PED 200 PIN
2000x1200

Packing Colour **unpacked on pallet**
M



Equipped with accessories



07

GATES

Safety gate system with different opening possibilities, ideated to be installed with our pedestrian barriers. Developed by following an innovative technical design that combines speed and simplicity during installation and cleaning. Available in different opening systems.

Sistema di cancelli di sicurezza ideati per completare le nostre barriere di protezione per aree pedonali. Progettati seguendo un innovativo disegno tecnico che coniuga rapidità e semplicità nelle fasi di installazione e pulizia. Disponibili molteplici sistemi di apertura.

Système de portillons résistant aux chocs étudié pour l'installation de nos barrières de protections pour les zones piétons. Portillons conçus suivant un design innovant qui combine rapidité et simplicité pendant le montage et le nettoyage. Différents systèmes d'ouvertures disponibles.

Sistema de puertas diseñado para completar nuestras barreras peatonales. Diseñado según un diseño técnico innovador que permite una instalación rápida y sencilla. Están disponibles varios sistemas de apertura.

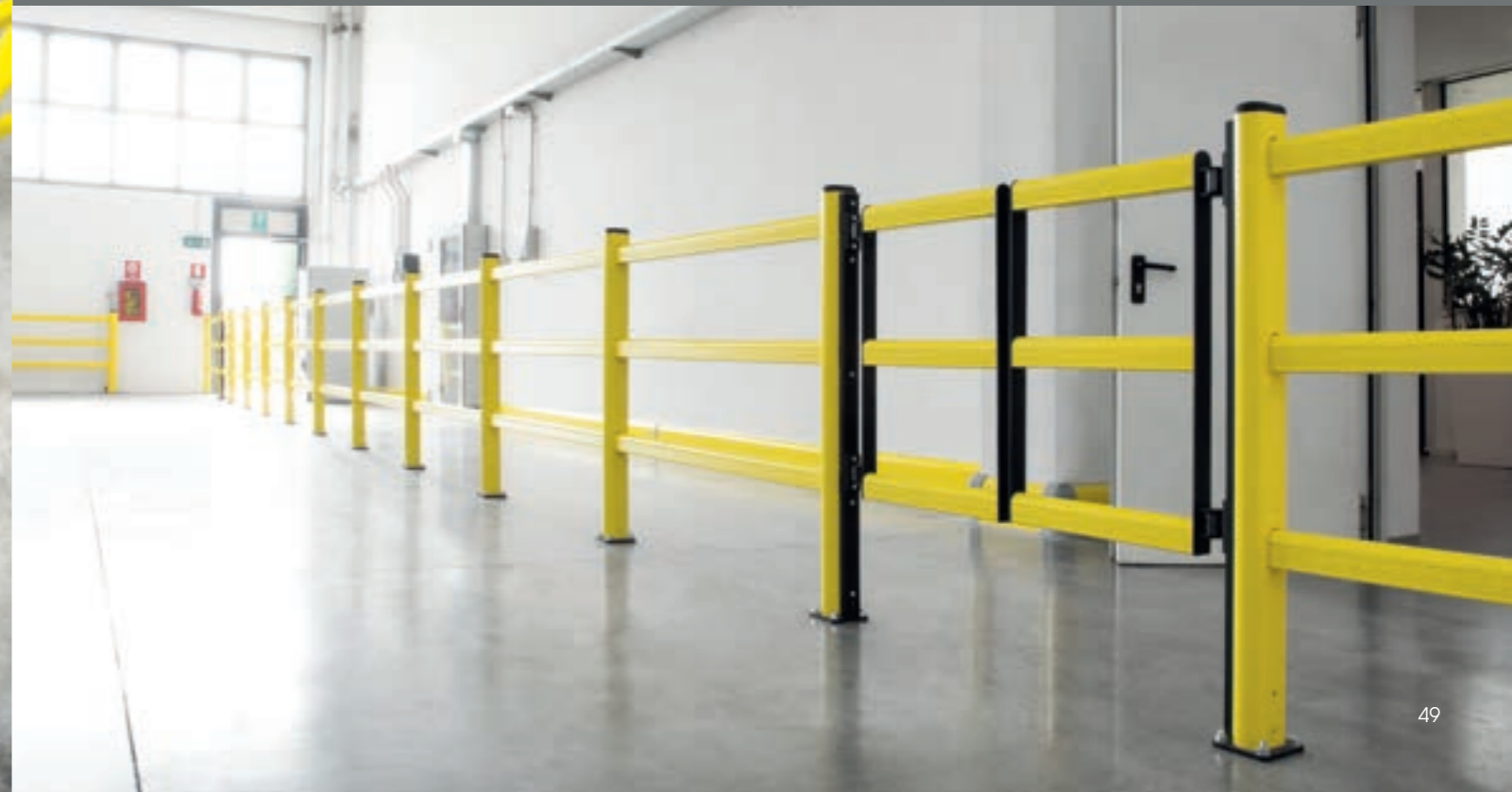

DOOR PEDESTRIAN 90

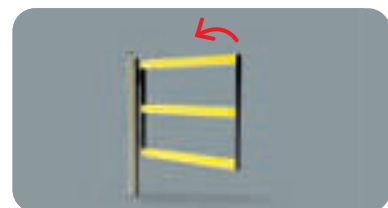

DP 90 ONE WAY

Packing Colour **to be defined**
M P



Equipped with accessories

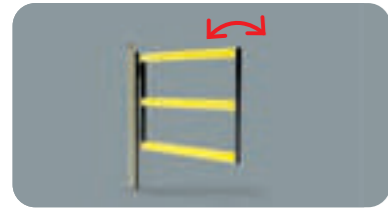

DP 90 SWING

Packing Colour **to be defined**
M P



Equipped with accessories

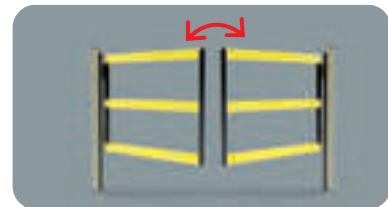

DP 90 SWING DOUBLE

Packing Colour **to be defined**
M P

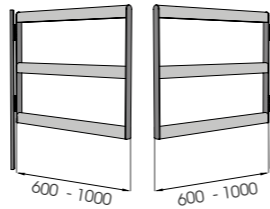

Equipped with accessories



DOOR PEDESTRIAN 150

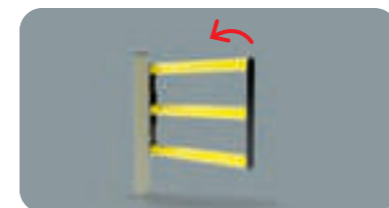

DP 150 ONE WAY

Packing Colour **to be defined**
M P

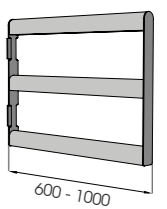

Equipped with accessories

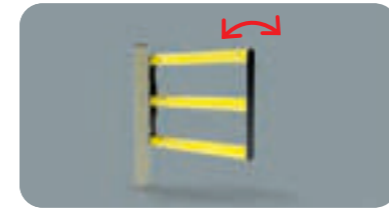

DP 150 SWING

Packing Colour **to be defined**
M P

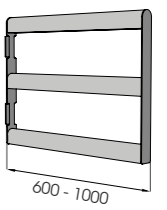

Equipped with accessories

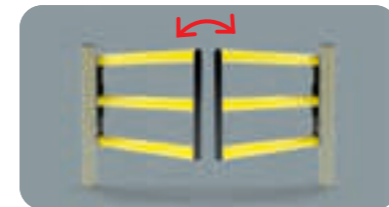

DP 150 SWING DOUBLE

Packing Colour **to be defined**
M P

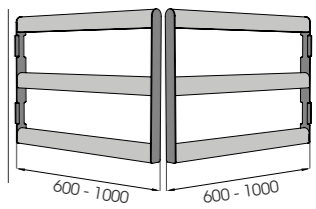

Equipped with accessories



LIFT GATE 90

DIFFERENT SIZES ON REQUEST

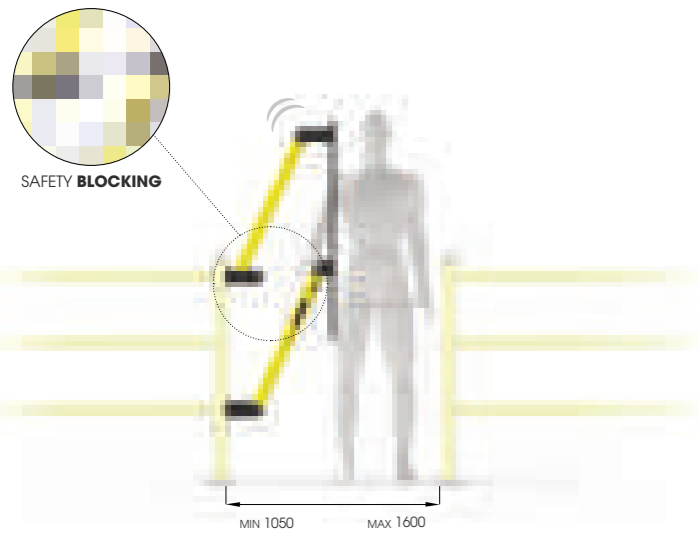

LIFT GATE 90 DOUBLE



DOUBLE GATE

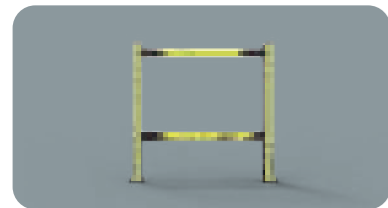
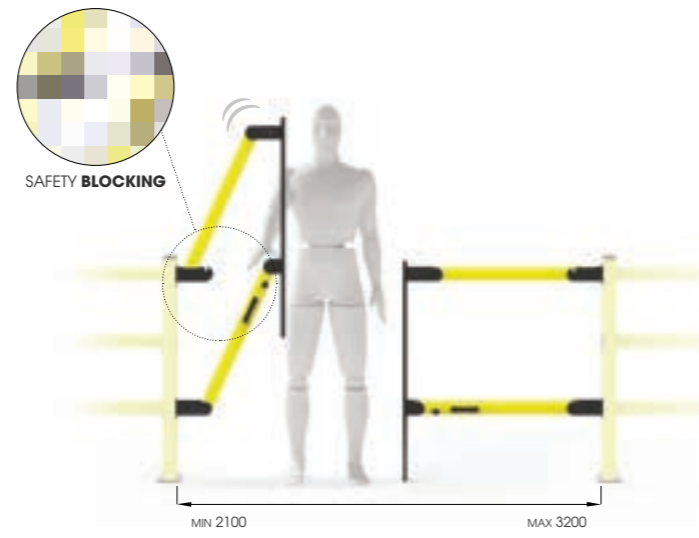

LIFT GATE 90

Equipped with accessories

Packing Colour **to be defined**
M P

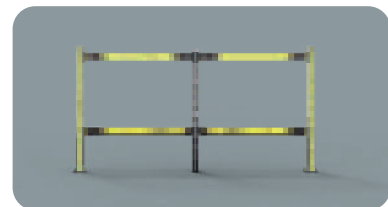

LIFT GATE 90 DOUBLE

Equipped with accessories

Packing Colour **to be defined**
M P

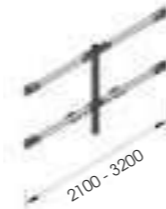

LIFT GATE 150

DIFFERENT SIZES ON REQUEST

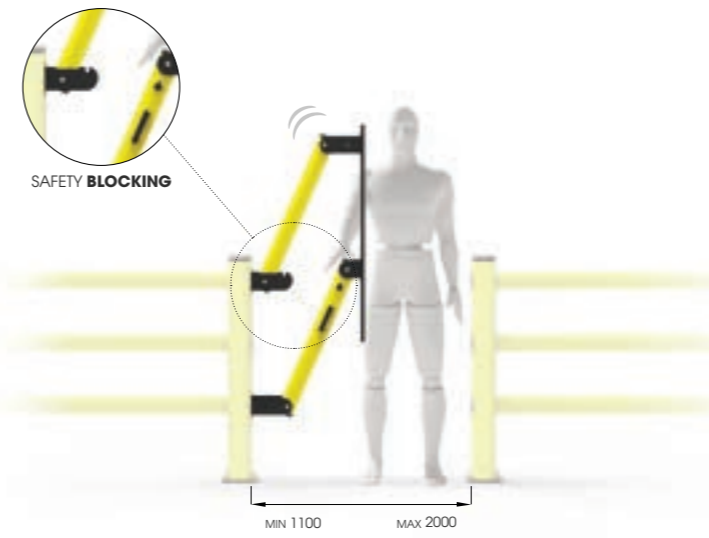

LIFT GATE 150 DOUBLE



DOUBLE GATE

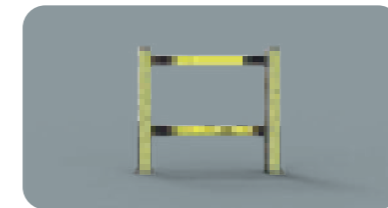
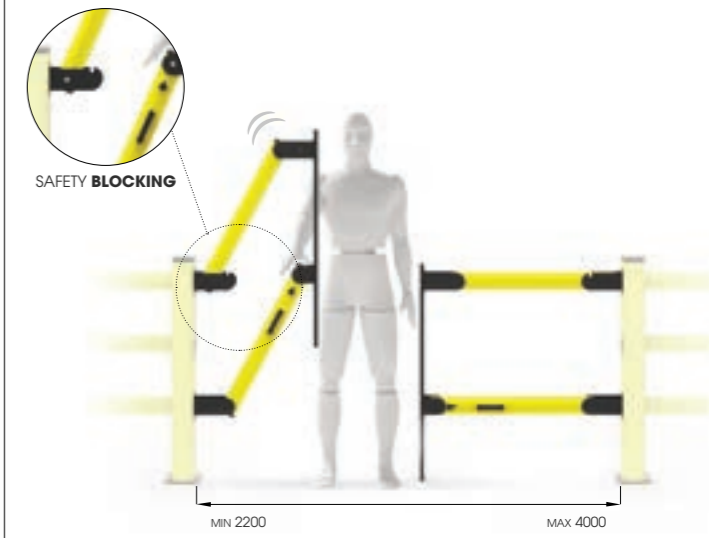

LIFT GATE 150

Equipped with accessories

Packing Colour **to be defined**
M P

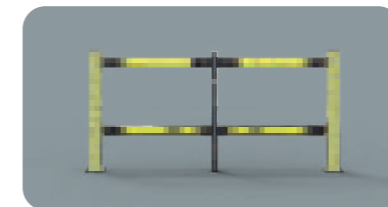

LIFT GATE 150 DOUBLE

Equipped with accessories

Packing Colour **to be defined**
M P

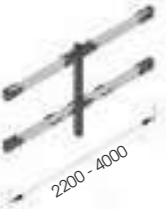

08

LINK

First adaptable barrier in the world thanks to the new connection system. Rail adjustable height, easy to set up, higher resistance in the most critical points.

Prima barriera al mondo regolabile a piacimento con nuovo sistema di raccordo. Altezza regolabile, facilmente componibile, resistenza potenziata nei punti più critici.

Première barrière au monde à modifier aux besoins avec un nouveau système de jonction. Hauteur à changer, facile à assembler et résistance renforcée aux points plus compliqués.

Primera barrera ajustable en el mundo gracias a un nuevo sistema de conexión. Altura ajustable, de fácil modularidad y resistencia potenciada en los puntos más críticos.

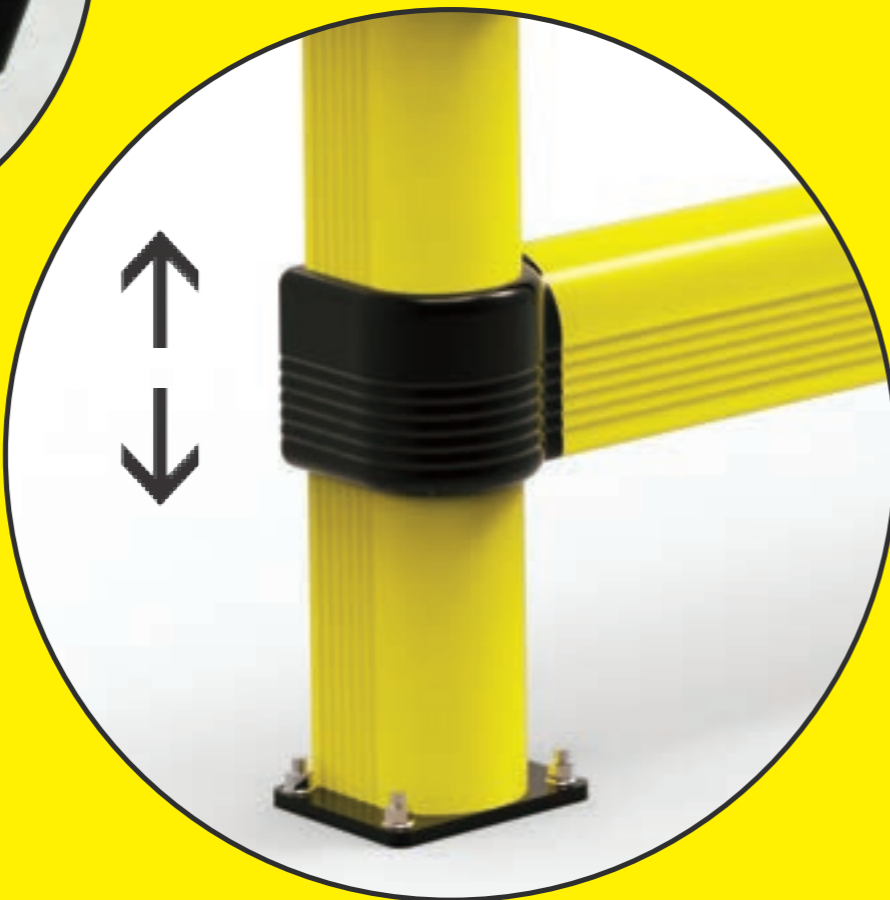

ADAPTABLE
HEIGHT



BASED ON
YOUR
NEEDS

LINK 150/3

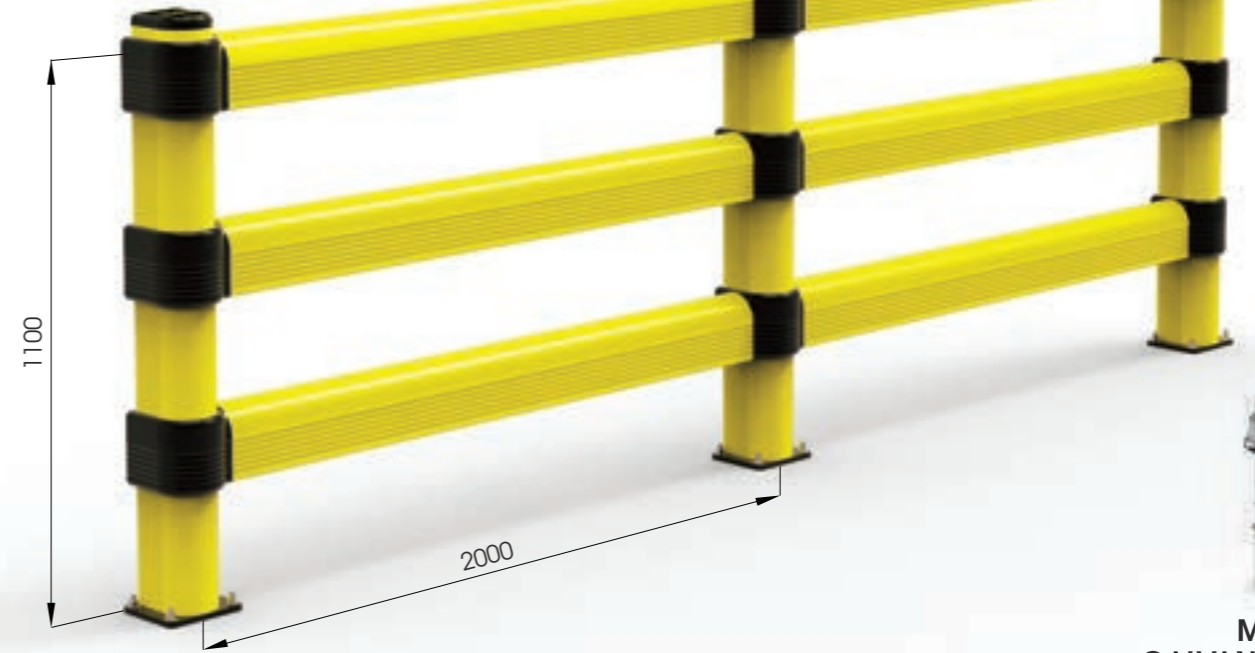

Link
DIFFERENT SIZES ON REQUEST



M12 GALVANISED STEEL

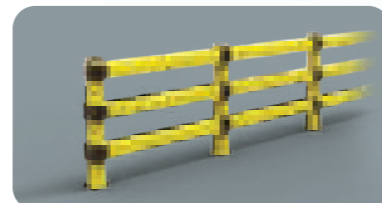

LINK 150/3

Equipped with accessories

Packing Colour **unpacked on pallet**
B M



LINK 150/3 CORNER

External Corners available

Equipped with accessories

Packing Colour **unpacked on pallet**
B M



LINK 150/2

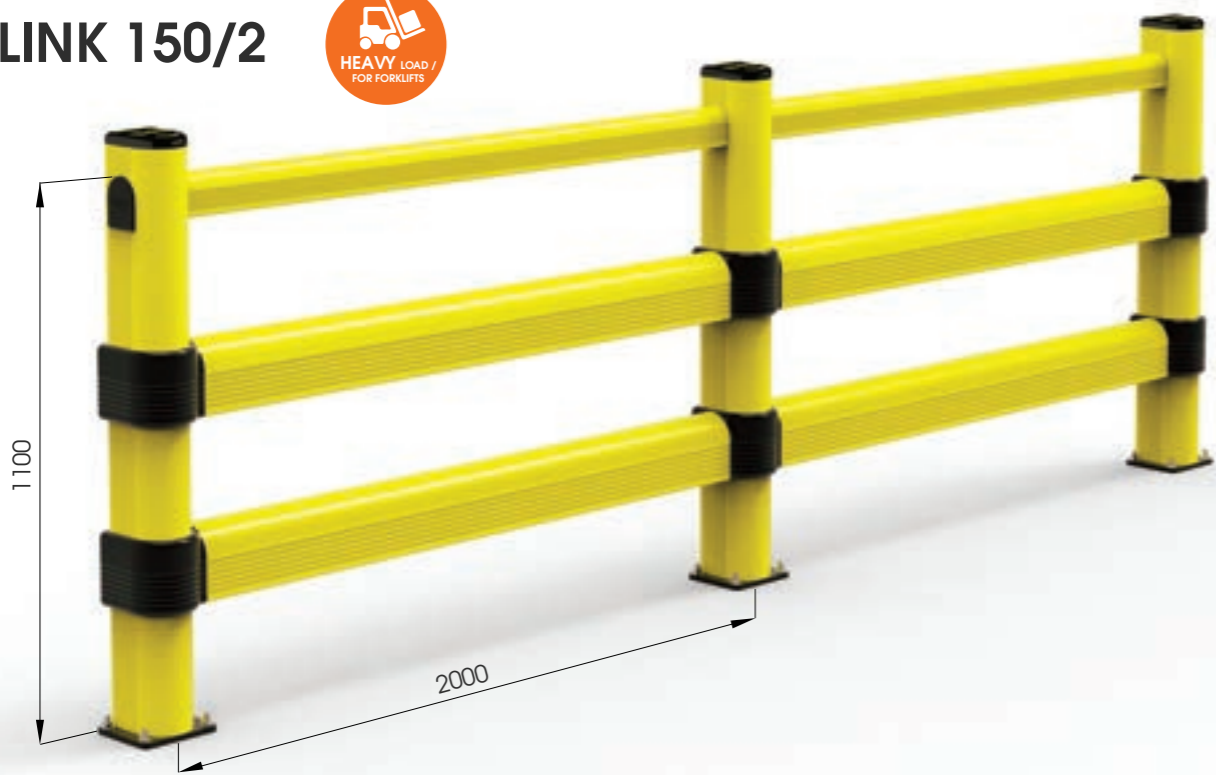

DIFFERENT SIZES ON REQUEST



LINK 150/1



DIFFERENT SIZES ON REQUEST

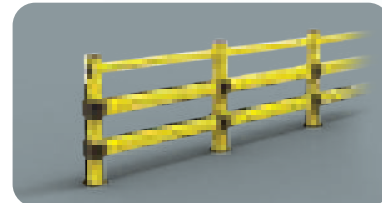

LINK 150/2

Equipped with accessories

Packing Colour **B** **M** unpacked on pallet

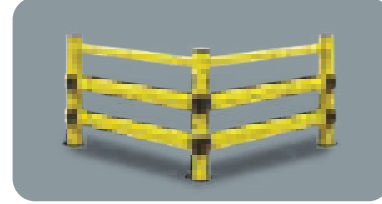
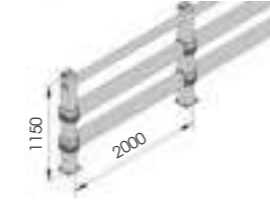

LINK 150/2 CORNER

External Corners available

Equipped with accessories

Packing Colour **B** **M** unpacked on pallet

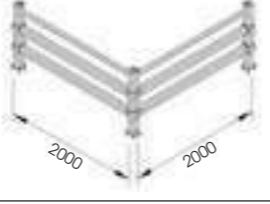

LINK 150/1

Equipped with accessories

Packing Colour **B** **M** unpacked on pallet

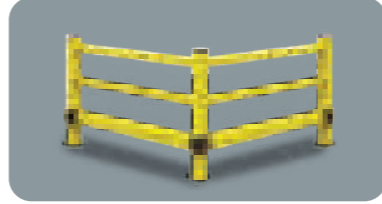

LINK 150/1 CORNER

External Corners available

Equipped with accessories

Packing Colour **B** **M** unpacked on pallet

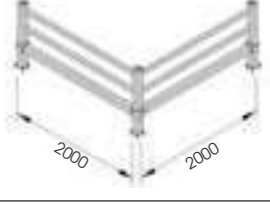

LINK LM



DIFFERENT SIZES ON REQUEST

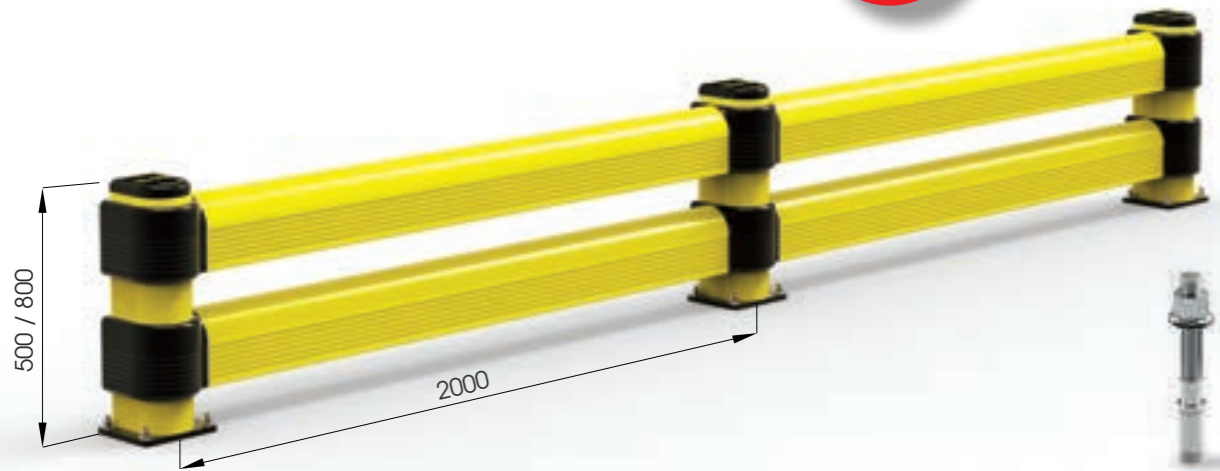

M12 GALVANISED STEEL



LINK LM 500 800

Equipped with accessories

Packing Colour **B** **M**



LINK LM CORNER

External Corners available

Equipped with accessories

Packing Colour **B** **M**

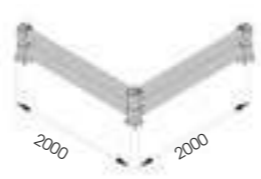

LINK SINGLE



DIFFERENT SIZES ON REQUEST

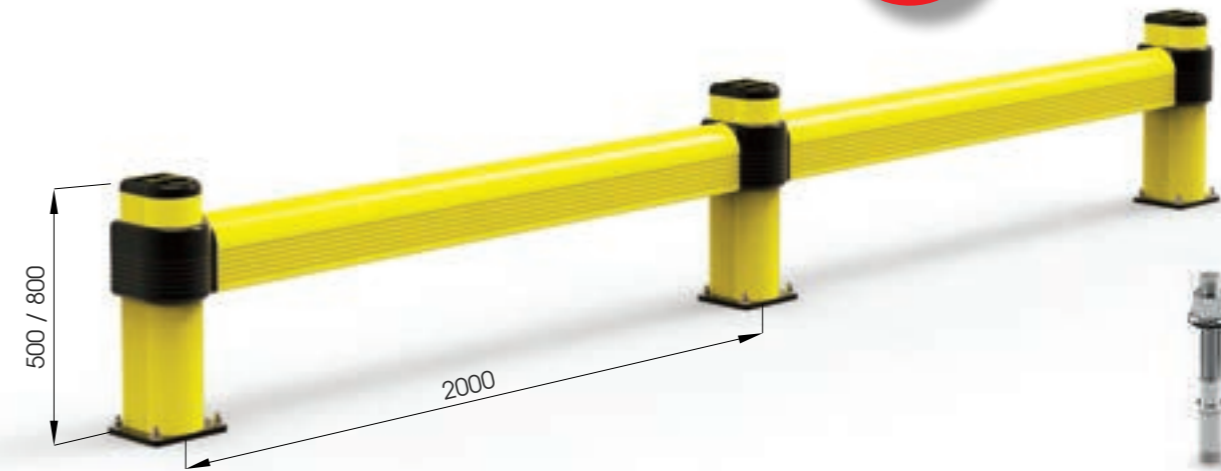

M12 GALVANISED STEEL



LINK SINGLE 500 800

Equipped with accessories

Packing Colour **B** **M**



LINK SINGLE CORNER

External Corners available

Equipped with accessories

Packing Colour **B** **M**



REMOVABLE PLATE

COVER 90 RE

AVAILABLE FOR:
SM / FENCE 90
HR 90 / PED 90



REMOVABLE PLATE

COVER 150 RE

AVAILABLE FOR:
LINK / LM
FENCE 150
PED 150



09

BFLEX

New protection system with a reinforced profile, twice as flexible and shock-absorbing. Planned and developed with a specific design to ensure high safety standards and to resist impacts from heavy loads. Available in many different versions.

Nuovo sistema di protezioni con profilo rinforzato, doppiamente flessibile e assorbente. Progettato e realizzato con un particolare design per garantire alti livelli di sicurezza e resistere all'impatto da carichi pesanti. Disponibile in diverse versioni.

Nouveau système de protection avec profil renforcé, doublement flexible et absorbant. Conçu et produit avec un design particulier pour assurer des niveaux élevés de sécurité et résister à l'impact des charges lourdes. Disponible en plusieurs versions.

Nuevo sistema de protección con perfil reforzado, más flexible y capaz de absorber perfectamente los impactos. Diseñado para asegurar el entorno laboral y para resistir a los impactos de cargas pesadas. Disponible en diferentes versiones.

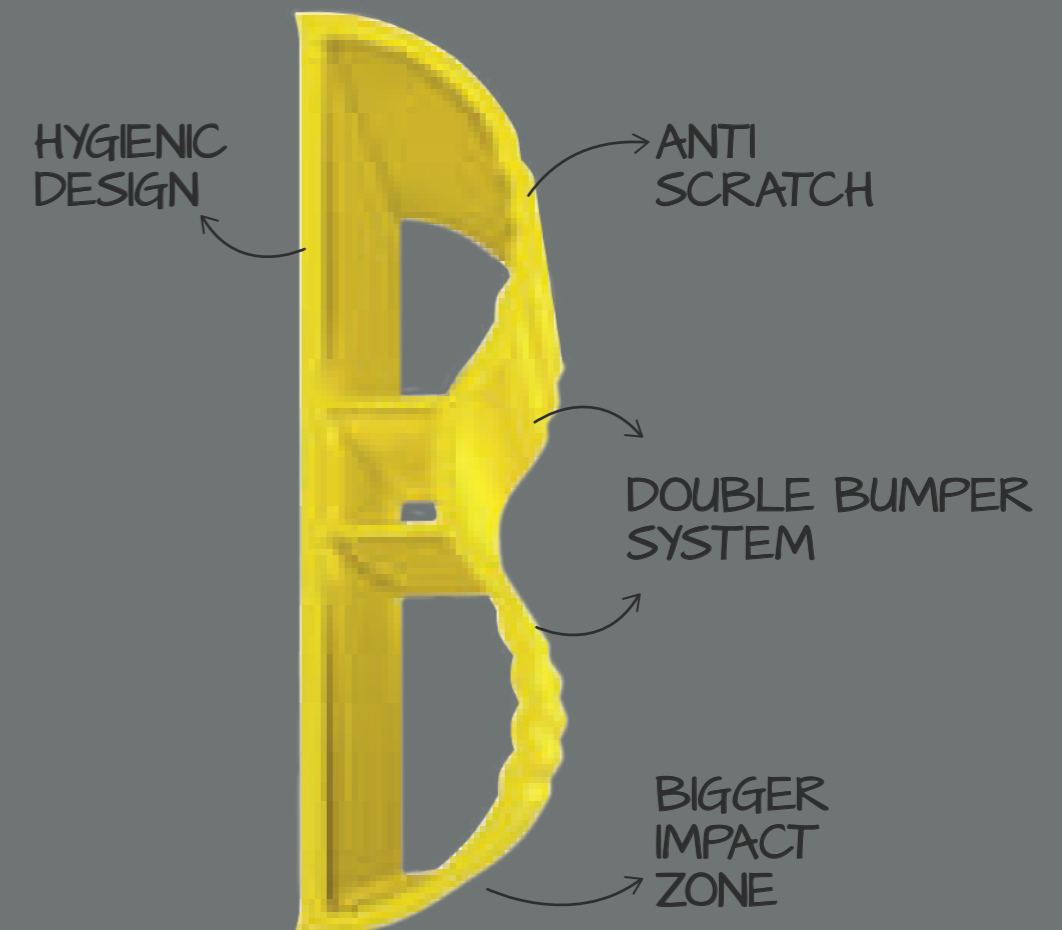

BFLEX.FRONT/1



BFLEX.FRONT/1 1100x450
BFLEX.FRONT/1 2400x450

Length 1.100 / 2.400 mm
Packing unpacked on pallet
Colour **M**

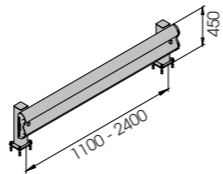

Equipped with accessories



BFLEX.FRONT/1 2000x450 MODULAR

Packing unpacked on pallet
Colour **M**

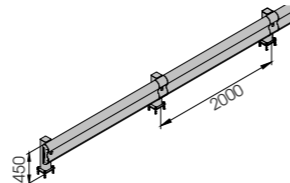

Equipped with accessories



BFLEX.FRONT/2

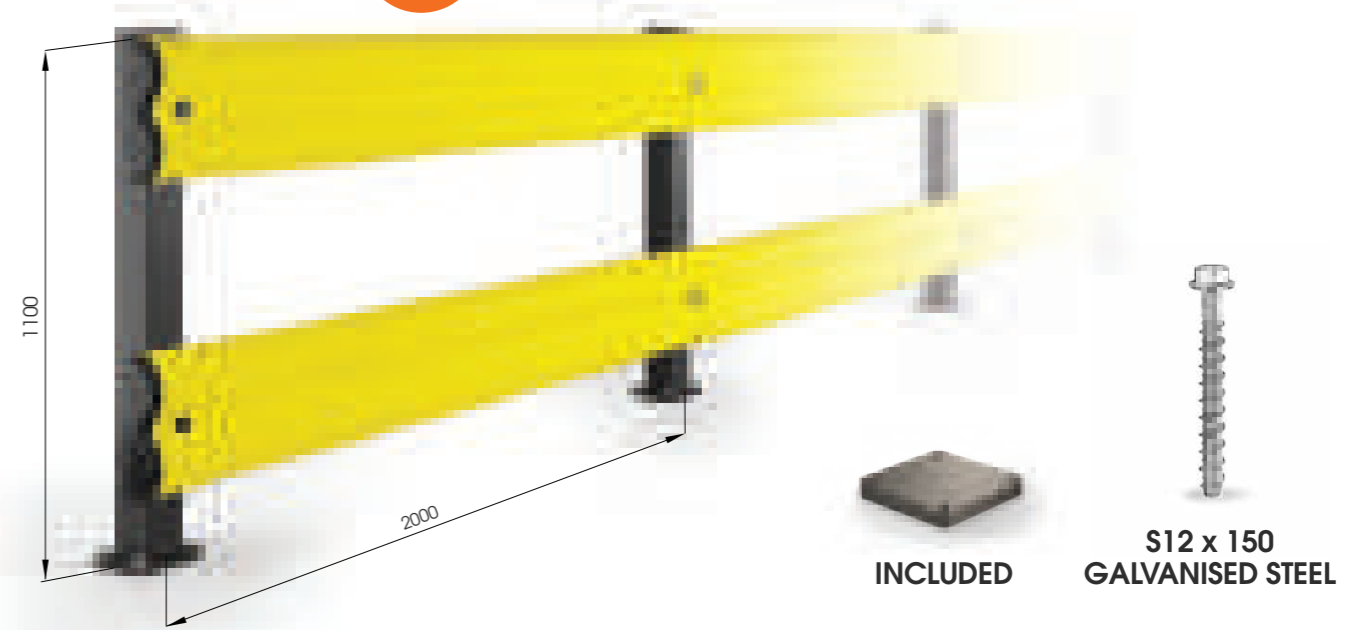

BFLEX.FRONT/2 1100x1100
BFLEX.FRONT/2 2400x1100

Length 1.100 / 2.400 mm
Packing unpacked on pallet
Colour **M**

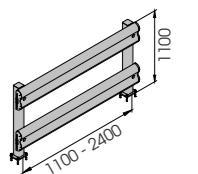

Equipped with accessories



BFLEX.FRONT/2 2000x1100 MODULAR

Packing unpacked on pallet
Colour **M**

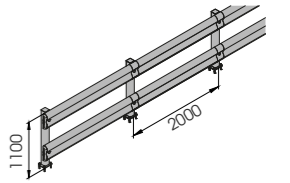

Equipped with accessories



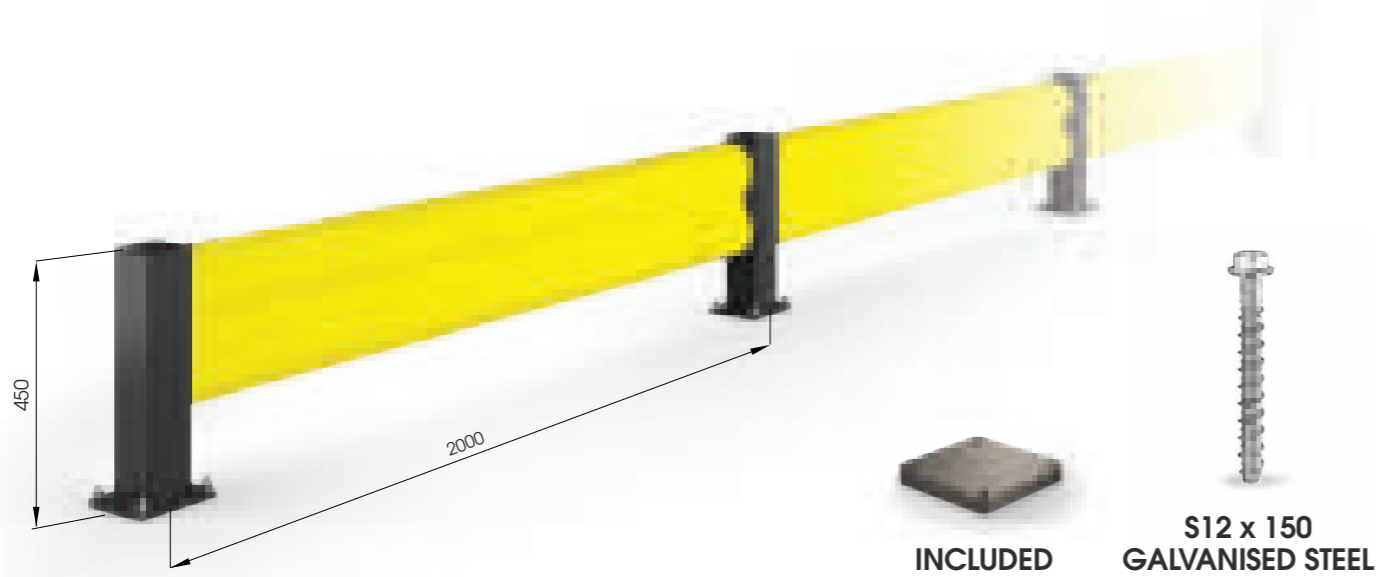

INCLUDED

S12 x 150
GALVANISED STEEL



BFLEX.COM/1 1100x450
BFLEX.COM/1 2400x450

Length 1.100 / 2.400 mm
Packing unpacked on pallet
Colour M

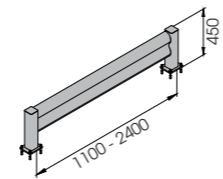

Equipped with accessories

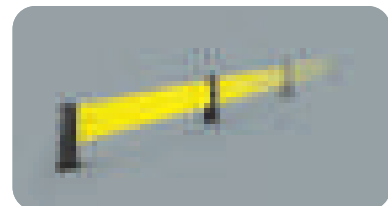

BFLEX.COM/1 2000x450
MODULAR

Packing unpacked on pallet
Colour M

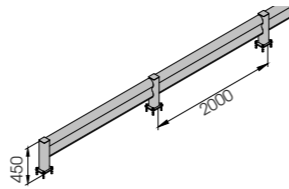

Corners available

Equipped with accessories

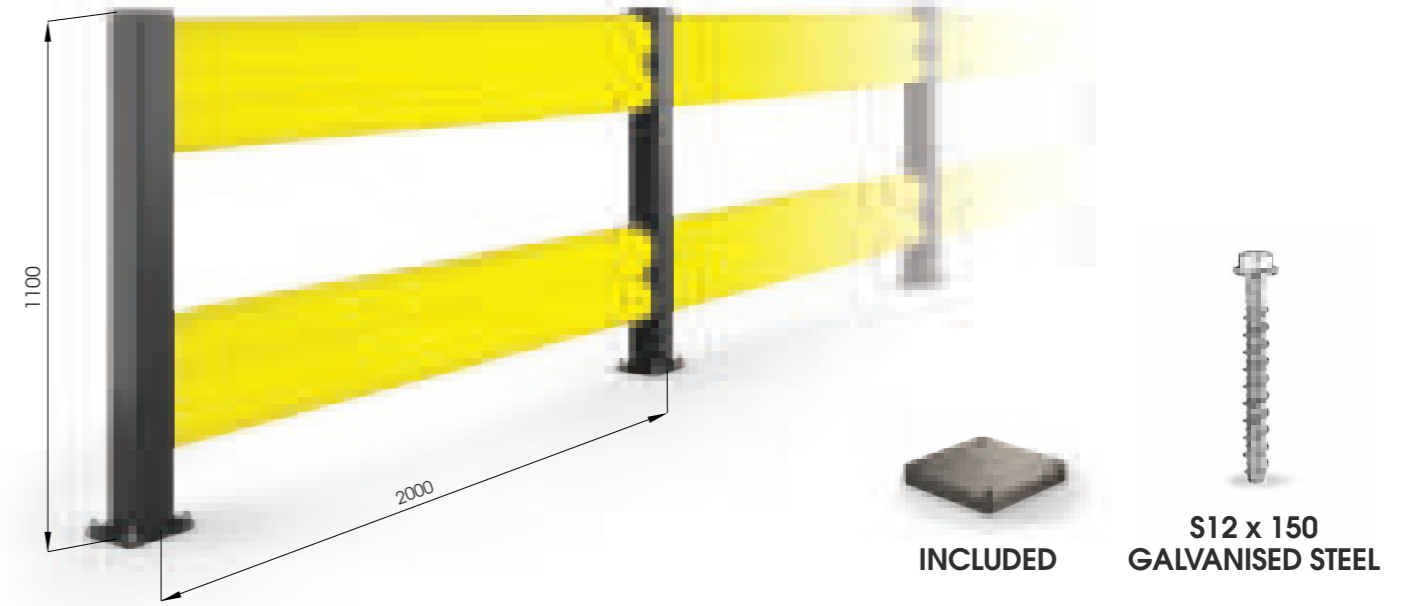

INCLUDED

S12 x 150
GALVANISED STEEL



BFLEX.COM/2 1100x1100
BFLEX.COM/2 2400x1100

Length 1.100 / 2.400 mm
Packing unpacked on pallet
Colour M

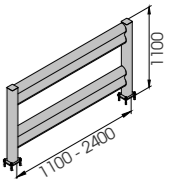

Equipped with accessories



BFLEX.COM/2 2000x1100
MODULAR

Packing unpacked on pallet
Colour M

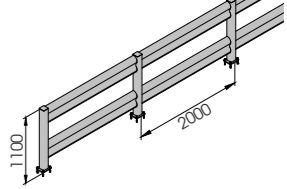

Corners available

Equipped with accessories



10

COLUMN PROTECTION

New bumper system specific for columns protection, strongly resistant to impacts from moving vehicles of different capacities, like pallet trucks and forklifts. Developed by following an innovative technical design that combines speed and simplicity during installation and cleaning. Available in different heights and fixing systems.

Sistema di profili specifico per la protezione delle colonne dai carrelli in movimento di varie portate. Progettato seguendo un innovativo disegno tecnico che coniuga rapidità e semplicità nelle fasi di installazione e pulizia. Disponibile in diverse altezze e tipologie di fissaggio.

Nouveau système bumper, spécifique pour protéger les pouteaux contre les mouvements des chariots. Étudié avec un modern dessin qui regroupe la rapidité et la facilité pendant l'installation et le nettoyage. Disponible en différents hauteurs et différents fixations.

Sistema de perfiles específico para la protección de las columnas de los carros en movimiento de diferentes capacidades. Diseñado según un innovador diseño técnico que une velocidad y simplicidad en las fases de instalación y limpieza. Disponible en diferentes alturas y tipos de fijación.



- REMOVABLE
- NO SCRATCHES
- VERY SOLID AND SLIM DESIGN
- NO FIXING IS REQUIRED

MINI HUG TOWER

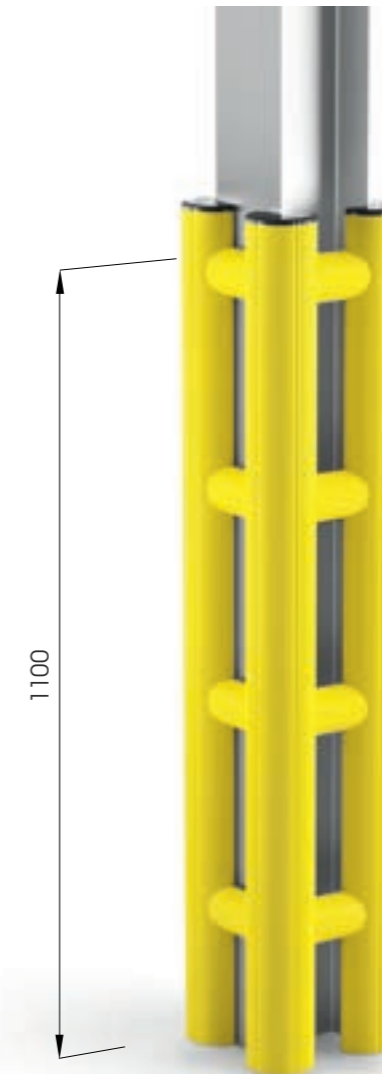

Column protection

DIFFERENT SIZES AND HEIGHT ON REQUEST

COMPACT



NO HOLES ON THE FLOOR AND COLUMN!



MINI HUG TOWER

Packing Colour to be defined M

Equipped with accessories

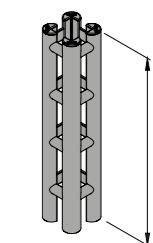

HUG TOWER 3 SIDES



DIFFERENT SIZES ON REQUEST



WALL FIXING WITH S8FH GALVANISED STEEL

COMPACT



NO HOLES ON THE FLOOR AND COLUMN!

WALL METAL BRACKET

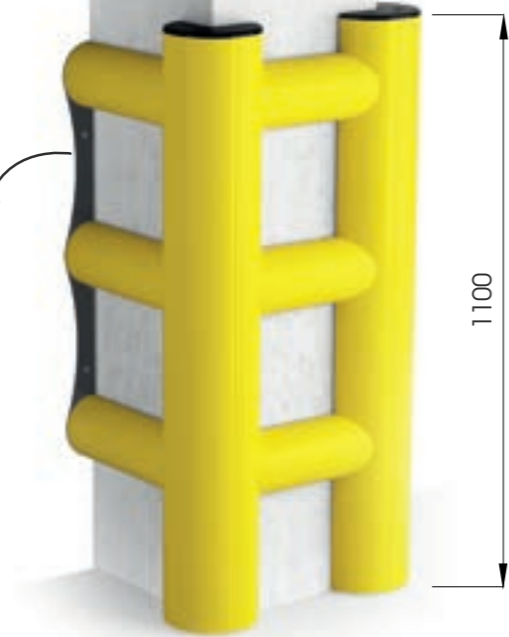

HUG TOWER



DIFFERENT SIZES AND HEIGHT ON REQUEST

COMPACT



NO HOLES ON THE FLOOR AND COLUMN!

CHOOSE THE HEIGHT YOU NEED!

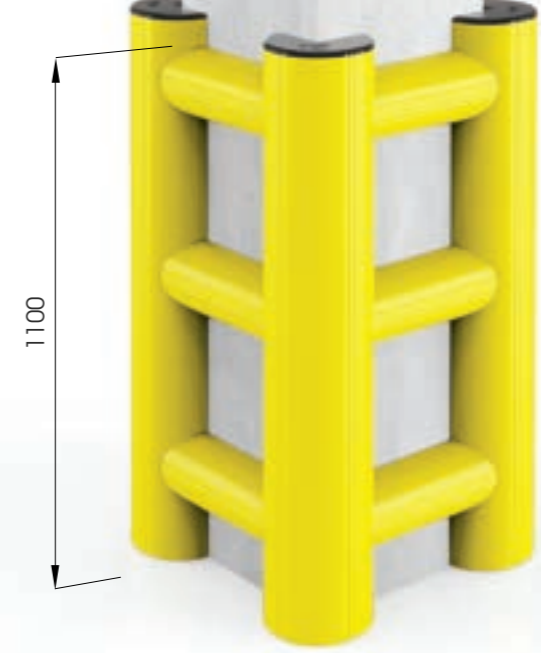
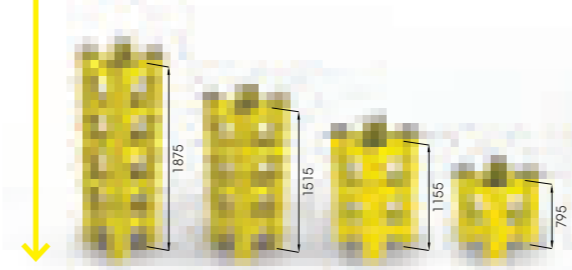

HUG TOWER 3 SIDES

Also 2 SIDES available

Equipped with accessories

Packing Colour **M** to be defined

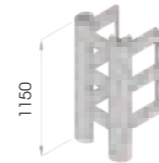

HUG TOWER

Equipped with accessories

Packing Colour **M** to be defined



TOWER PROTECTION



DIFFERENT SIZES AND HEIGHT ON REQUEST



M12 GALVANISED STEEL

AVAILABLE ALSO:

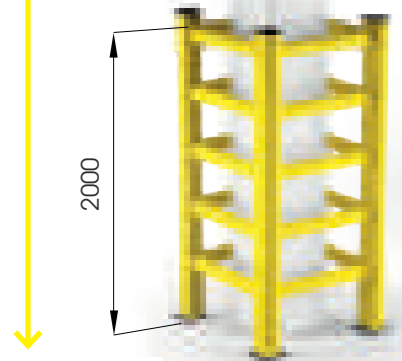

TOWER
Also 2/3 SIDES available

Equipped with accessories

Packing Colour to be defined
B M



TOWER LINK



DIFFERENT SIZES AND HEIGHT ON REQUEST



M12 GALVANISED STEEL



1100

OPTIONS

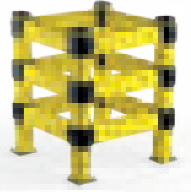
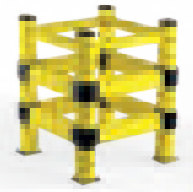
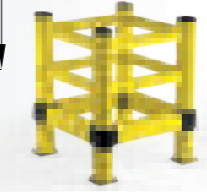

TOWER LINK/1

TOWER LINK/2

TOWER LINK/3

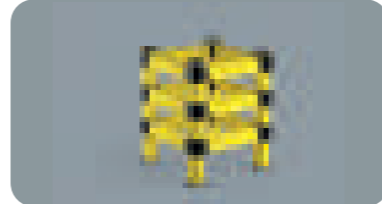

TOWER LINK/1
TOWER LINK/2
TOWER LINK/3

Equipped with accessories

Packing Colour to be defined
B M

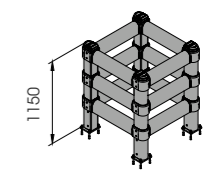

COLUMN PROTECTION 90



DIFFERENT SIZES ON REQUEST

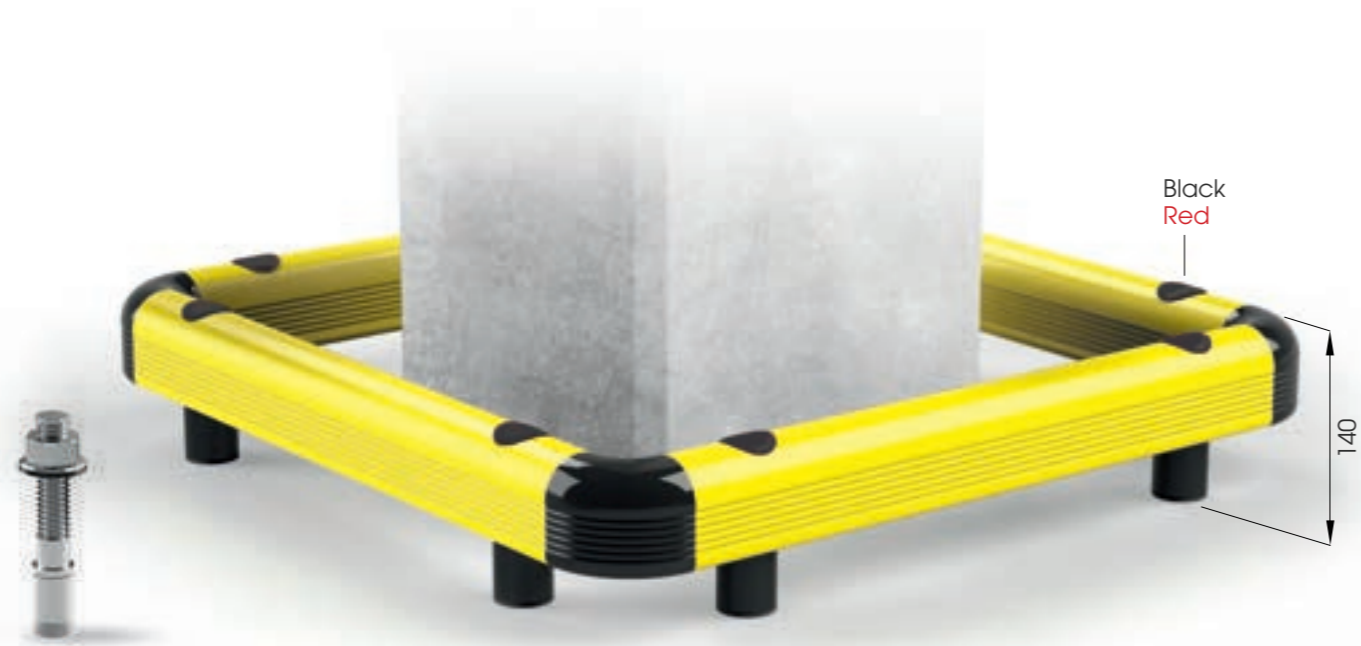

M16
STAINLESS STEEL



COPRO 90

Also 2/3 SIDES available

Equipped with accessories

Packing Colour **unpacked on pallet**



COLUMN PROTECTION 150



DIFFERENT SIZES ON REQUEST

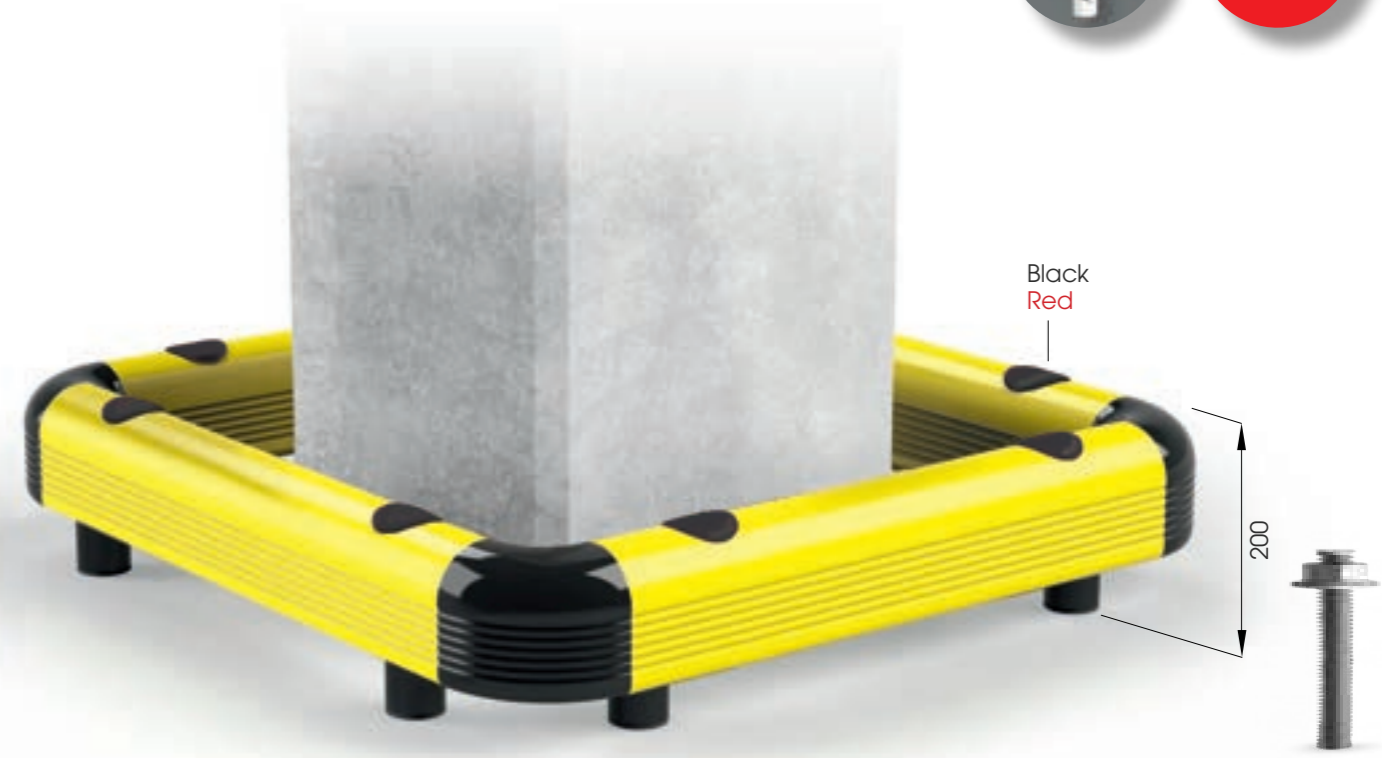

SF20
STAINLESS STEEL



COPRO 150

Also 2/3 SIDES available

Equipped with accessories

Packing Colour **unpacked on pallet**

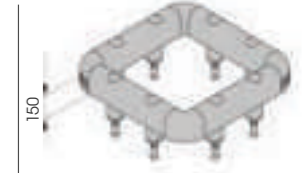

11

DOOR FRAME PROTECTION

Protection system designed to prevent forklifts collisions with overhead infrastructure and gates and doors jambs. It is created to keep under control the passage of forklifts that exceed height limits, attracting the attention of drivers and inviting them to a more careful guide. Useful to protect gates, loading docks or overhead assets. Available in different lengths.

Sistema di protezione ideato per prevenire le collisioni dei carrelli elevatori in movimento con le infrastrutture sopraelevate e gli stipiti di porte e portoni. Limita il passaggio di carrelli che superano i limiti di altezza, attirando l'attenzione dei carrellisti e invitandoli ad una guida più accorta. L'installazione è consigliata in prossimità di portoni, baie di carico o di attrezzature sospese. Disponibile in diverse lunghezze.

Systèmes de protection conçus pour prévenir les collisions des chariots élévateurs en mouvement avec les infrastructures en hauteur et les montants des portes. Utiles pour empêcher le passage des chariots élévateurs qui dépassent les limites d'hauteur, pour attirer l'attention des conducteurs et de les habituer à faire plus attention à la conduite des chariots. C'est installé en proximité des bords des portes, quais de chargement et infrastructures suspendues. Disponible en plusieurs longueurs.

Sistema de protección diseñado para evitar la colisión de carretillas elevadoras en movimiento con infraestructuras, instalaciones elevadas y marcos de puertas industriales. Diseñada para limitar el paso de las carretillas que superan los límites de altura, llamando la atención de los conductores de montacargas e invitándoles a conducir con más cuidado. Se recomienda su instalación cerca de puertas industriales, muelles de carga o equipos suspendidos. Disponible en varias longitudes.

WARNING BAR

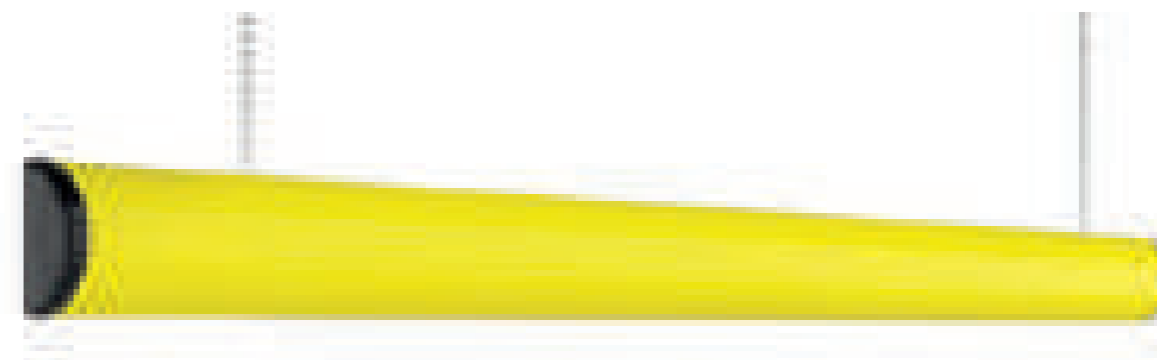

WBAR

Equipped with accessories

Length 2000 / 3000 mm
Packing to be defined
Colour M

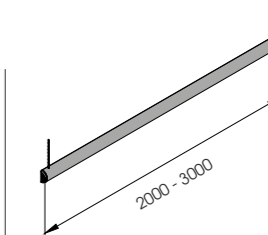

WARNING BAR / INFORMATION SIGN

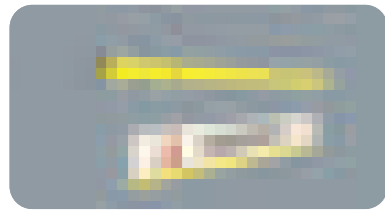

WBIS

Equipped with accessories

Length 2000 / 3000 mm
Packing to be defined
Colour **M**

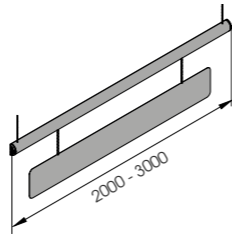

WARNING BAR / LIGHT & SOUND



WBLS

Snap hooks and chains included

Equipped with accessories

Length 2000 / 3000 mm
Packing to be defined
Colour **M**

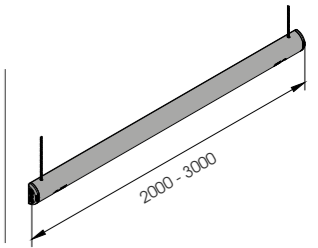

FULL FRAME SELF STANDING



DIFFERENT SIZES ON REQUEST

FAST AND EASY TO INSTALL

INNOVATIVE BIGGER PLATES!

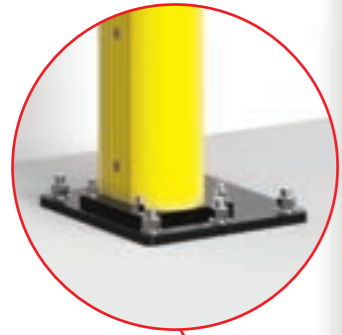

FFB SELF STANDING

Packing Colour **to be defined**
M



Equipped with accessories



FULL FRAME WALL FIXING



DIFFERENT SIZES ON REQUEST

FAST AND EASY TO INSTALL

WALL FIXING ACCESSORIES

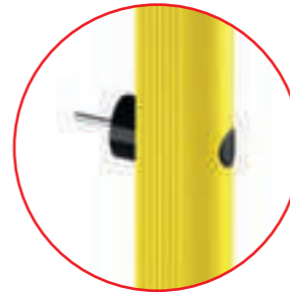

FFB WALL FIXING

Packing Colour **to be defined**
M



Equipped with accessories



12

LOADING BAY PROTECTION

Sistema di protezione antiurto installato in prossimità delle porte di carico. Permettono di evitare situazioni ad alto rischio di scivolamento, caduta e ribaltamento dei mezzi in movimento in presenza di baie di carico aperte e non presidiate.

Système de protection contre les chocs installé près des portes de chargement. Ils permettent d'éviter des situations en raison du risque élevé de glissement, de chute et de basculement des véhicules en mouvement en présence de quais de chargement ouverts et sans surveillance.

Sistema de protección antigolpes que está cerca de los muelles de carga. Evitan los riesgos de deslizamiento, caída y derrocamiento de los vehículos en movimiento cuando están cerca de esta zona.

Loading bays protections are shock-proof solutions which are set up near loading doors. They avoid possible slipping, falling and flipping of moving vehicles near open and unmanned loading bays.



NEW

DOCK BUMPER



S16 GALVANISED STEEL



DOCK BUMPER

Packing to be defined

Equipped with accessories

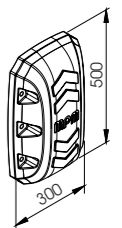

NEW

Loading Bays Protections

HUG GATE



M12 GALVANISED STEEL



HUG GATE

Equipped with accessories

Packing Colour **to be defined**

B M



Loading Bays Protections

DOCK GATE



M12 GALVANISED STEEL



DOCK GATE L 2400-2600
DOCK GATE XL 2605-2800
DOCK GATE XXL 2805-3000

Equipped with accessories

Packing Colour **to be defined**

B M

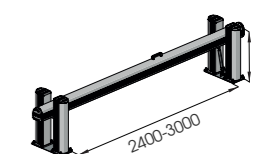

13

WHEEL STOP

Solutions designed for the safety of loading and unloading zones in warehouses and parking areas. Ideal for conveying, stopping or positioning the vehicle in the parking area, or near a cargo bay.

Soluzioni progettate per la sicurezza delle zone di carico e scarico dei magazzini e dei parcheggi. Ideali per convogliare, fermare o posizionare il mezzo nell'area di parcheggio o in prossimità di una baia di carico.

Solutions conçues pour la sécurité des zones de chargement et de déchargement des entrepôts et parkings. Idéal pour transporter, arrêter ou positionner le véhicule dans l'aire de stationnement ou à proximité d'un quai de chargement.

Soluciones diseñadas para asegurar las zonas de carga y descarga de almacenes y aparcamientos. Ideal para transportar, detener o posicionar el vehículo en la zona de aparcamiento o cerca de un muelle de carga.

Wheel stop

TRUCK LINE



DIFFERENT SIZES ON REQUEST



SF20 x 200
STAINLESS STEEL

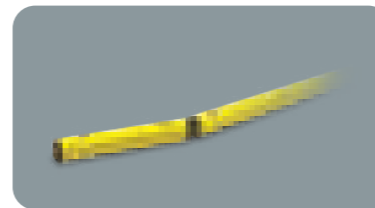

TL	500	2000
	750	3000
	1000	4000
	1500	

Packing Colour **to be defined**
B M



Equipped with accessories



CAR STOP

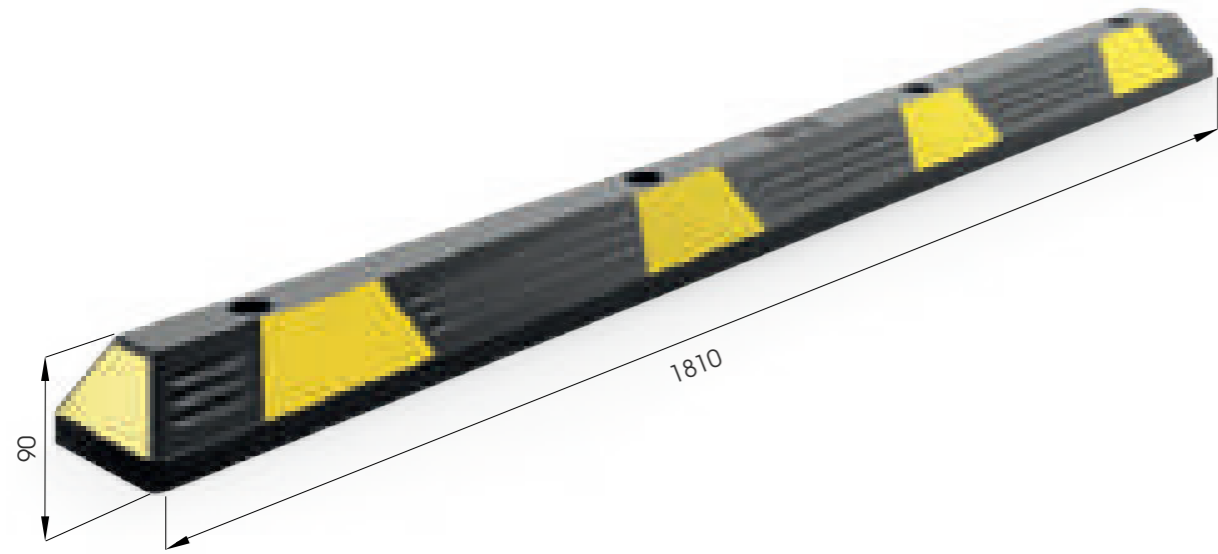

CAR STOP

Packing **to be defined**

Fixing on requests

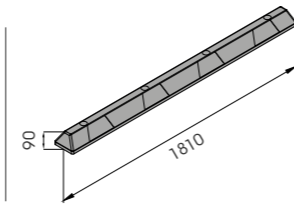

TRUCK STOP



TRUCK STOP

Packing **to be defined**

Fixing on requests

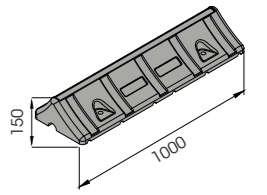

14

CABLE COVER

Soft recycled material. Space-saving, resistant and easy-to-install, our cable cover is perfectly suitable for work areas with pedestrian passages.

Sistema di protezione morbido a pavimento per cavi, realizzato con materiale riciclato. Passacavi poco ingombrante, resistente e facile da posare. Adatto ad aree di lavoro con passaggio di pedoni.

Système de protection de sol souple pour câbles. Guide-câble peu encombrant, résistant et facile à installer. Convient aux zones de travail avec passage piéton.

Sistema de protección blando de suelo para los cables realizado con material reciclable. Pasacables que ahorra espacio, duradero y fácil de instalar. Adecuado para zonas de trabajo con tráfico peatonal.

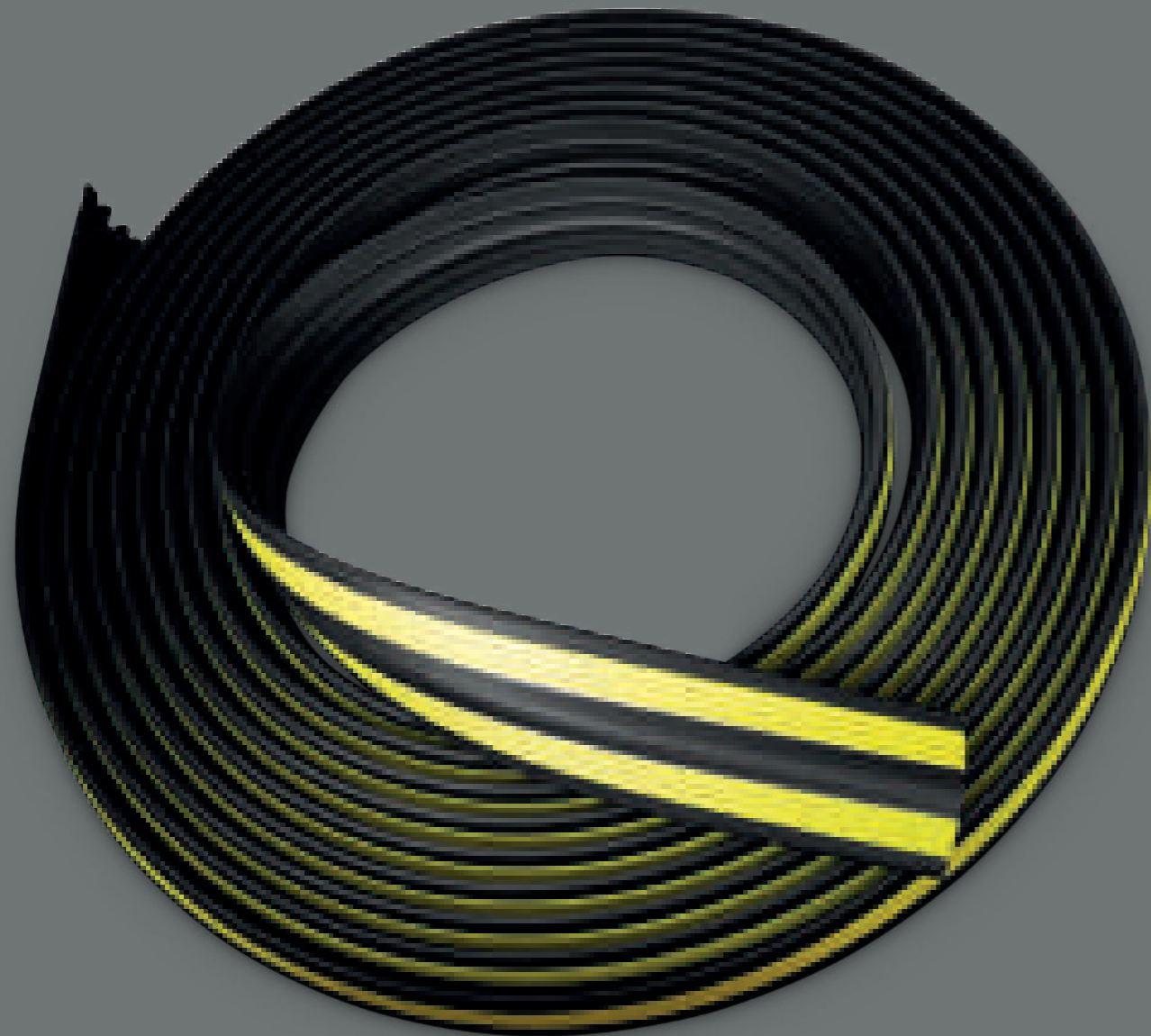

CABLE COVER



CAB CO 10 - 20 - 10

Length 1.000 / 3.000 mm - 10.000 mm
Packing 8 pz / box - 1 pz / box

Recycled Material

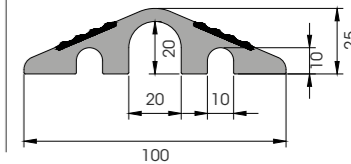

15 CORNER PROTECTION

Designed to protect pillars and columns or external corners of walls and panels.

Realizzato per proteggere pilastri e colonne o angoli esterni di muri e pannelli.

Etudié pour protéger les poteaux et les colonnes ou les angles extérieurs de murs et de panneaux.

Realizado para proteger pilares y columnas o esquinas exteriores de paredes y paneles.

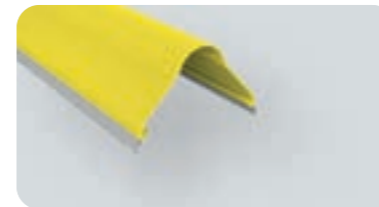

CP 100

Length 4.000 mm
Packing 10 pz / box
Colour B M E F

Length 2.000 mm
Packing 10 pz / bag
Colour M



CPF 100

Length 4.000 mm
Packing 10 pz / bag

Length 2.000 mm
Packing 10 pz / bag



CPT 100

Packing 40 pz / box
Colour B E F

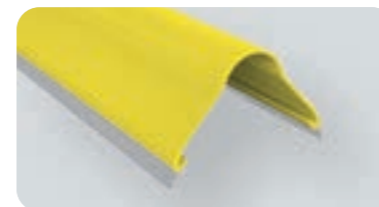
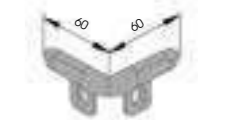

CP 200

Length 4.000 mm
Packing 2 pz / bag
Colour B M E

Length 2.000 mm
Packing 2 pz / bag
Colour M



CPF 200

Length 2.000 / 4.000 mm
Packing 2 pz / bag



CPT 200

Packing 20 pz box
Colour B E

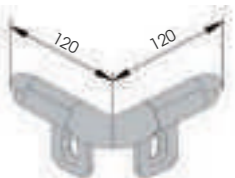

16

KERB

Large-sized protection system, ideal for walls and panels. Easy to install and clean. Fully equipped with corner caps and buttons.

Sistema di protezione di grandi dimensioni, ideale per muri e pannelli. Facile da installare e pulire. Completo di angolari e tappi.

Système de protection de grands dimensions, idéal pour les murs et les panneaux. Facile à installer et à nettoyer. Complété de bouchons d'angles et d'embouts.

Sistema de protección de grande dimensión, ideal para paredes y paneles. Fácil de instalar y limpiar. Completo de esquinas y tapas.

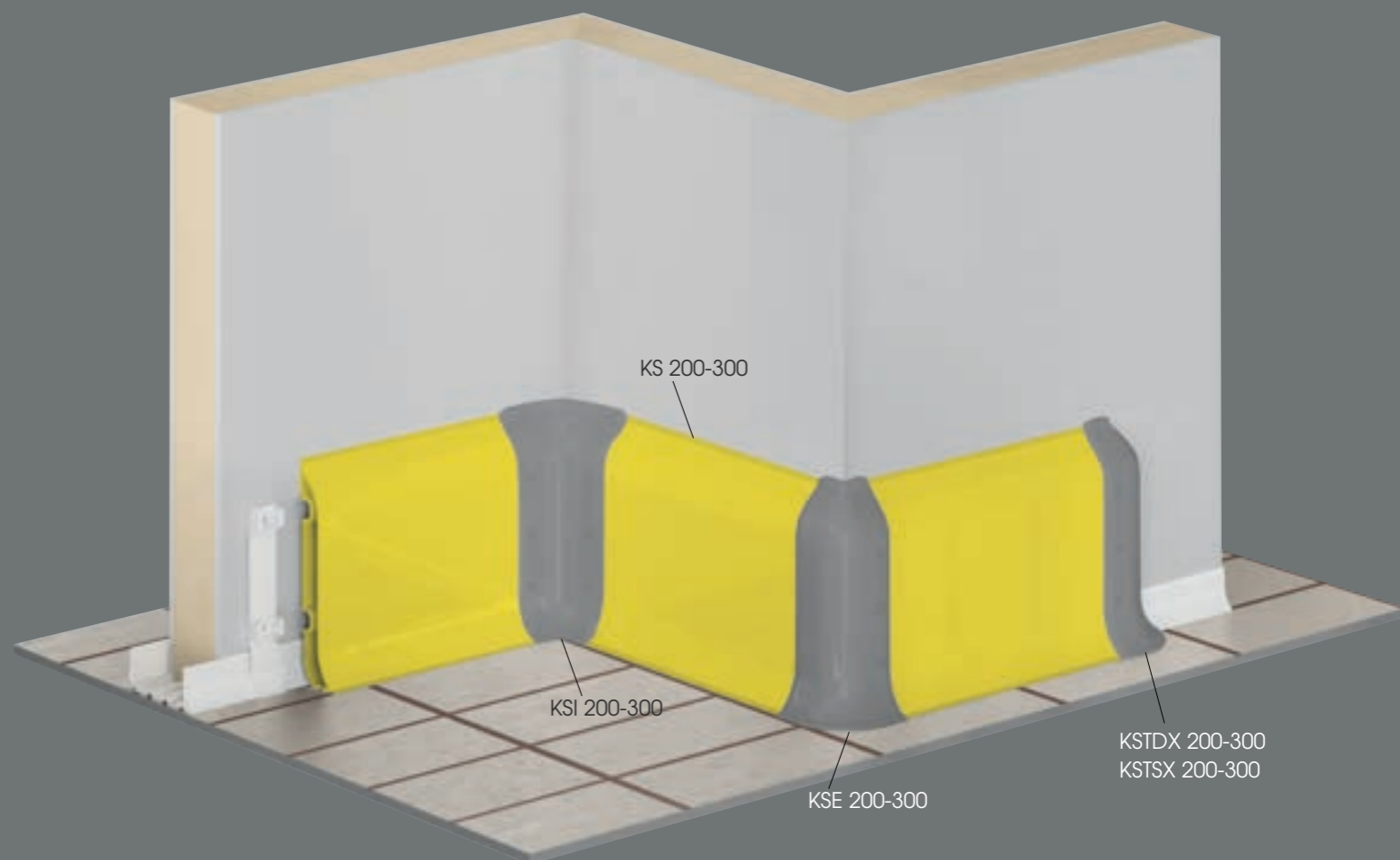



KS 200

Length **4.000 mm**
 Packing **3 pz / box**
 Colour **B M E**

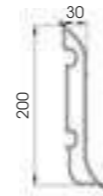

KEPF 200

To install with TB14

Packing **50 pz / box**
 Colour **K**

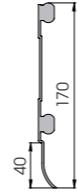

KSJ 200

To install with TB14 / TF14

Packing **20 pz / box**
 Colour **B E**

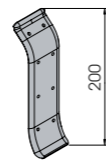

KSI 200

To install with TB14 / TF14

Packing **20 pz / box**
 Colour **B E**

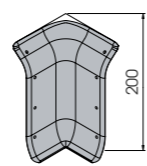

KSE 200

To install with TB14 / TF14

Packing **20 pz / box**
 Colour **B E**

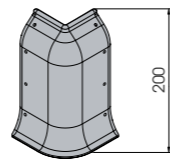

KSTD/SX 200

To install with TB14 / TF14

Packing **20 pz / box**
 Colour **B E**

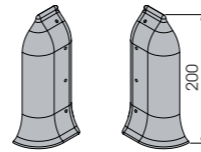

KSJ 200 LT



FLEXIBLE JOINT

Packing **to be defined**
 Colour **K**

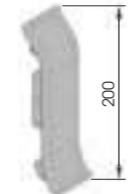

KS 300

Length **4.000 mm**
 Packing **1 pz**
 Colour **M E**

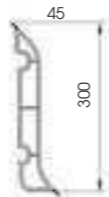

KEPF 300

To install with TB20

Packing **40 pz / box**

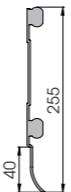

KSJ 300

To install with TB20 / TF20

Packing **10 pz / box**
 Colour **B E**

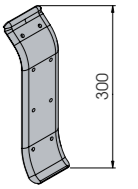

KSI 300

To install with TB20 / TF20

Packing **10 pz / box**
 Colour **B E**

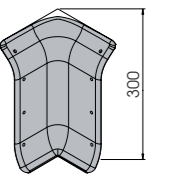

KSE 300

To install with TB20 / TF20

Packing **10 pz / box**
 Colour **B E**

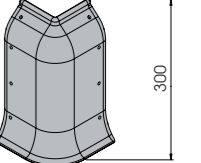

KSTD/SX 300

To install with TB20 / TF20

Packing **10 pz / box**
 Colour **B E**

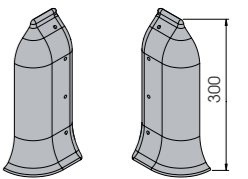

17

WALL PROTECTION

New bumper without guides. Thanks to its big size and resistance it is ideal for protection of industrial spaces. Fixed caps with hidden screws covered by specific buttons.

Nuovo profilo antiurto senza guida. La sua ampiezza e resistenza lo rende ideale per la protezione di ambienti industriali. Terminali fissati con viti nascoste da appositi bottoni.

Nouveau profilé anti-choc sans besoin d'une base à fixer. Sa mesure large et sa résistance en font le profilé parfait pour la protection des espaces industriels. Embouts fixés avec des vis cachées grâce à des bouchons spécifiques.

Nuevo perfil antigolpe sin guía. Su amplitud y resistencia lo hacen ideal para la protección de entornos industriales. Terminales fijados con tornillos ocultos por botones especiales.



Wall Protection

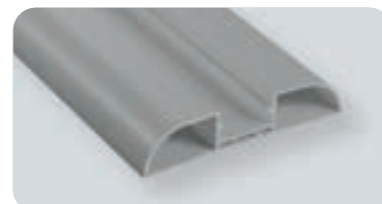

WP 100

Length **4.000 mm**
Packing **8 pz / box**
Colour **B E F**

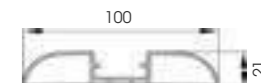

WP 150

Length **4.000 mm**
Packing **4 pz / box**
Colour **B M E**

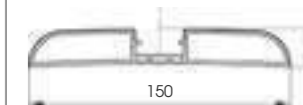

WPC

To install with WP 100 / WP 150

Length **4.000 mm**
Packing **16 pz / box**
Colour **A B M D E F G H**



WPT 100

To install with TM5

Packing **50 pz / box**
Colour **B E F**



WPA 100

To install with TS9

Packing **20 pz / box**
Colour **B E**

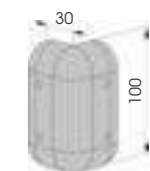

WPT 150

To install with TM5

Packing **50 pz / box**
Colour **B E**



WPA 150

To install with TS9

Packing **20 pz / box**
Colour **B E**



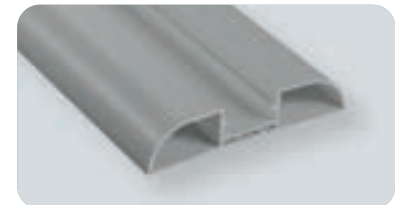
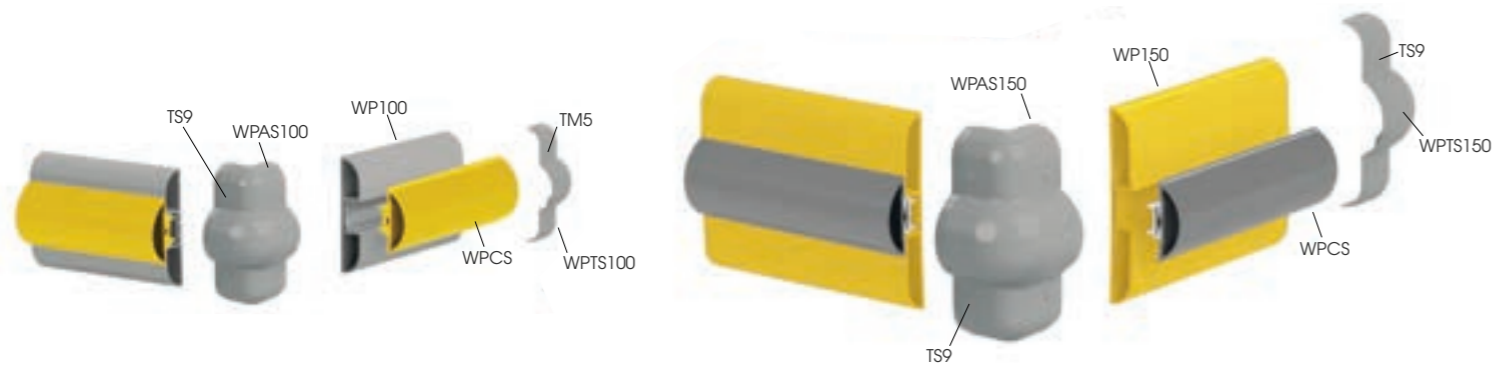

WP 100

Length **4.000 mm**
Packing **8 pz / box**
Colour **B E F**

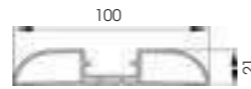

WP 150

Length **4.000 mm**
Packing **4 pz / box**
Colour **B M E**

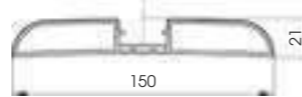

WPCS

To install with WP 100 / WP 150



Length **4.000 mm**
Packing **8 pz / box**
Colour **A B M D E F G H I**

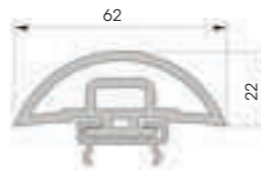

WPTS 100

To install with TS9

Packing **20 pz / box**
Colour **B E**



WPAS 100

To install with TS9

Packing **20 pz / box**
Colour **B E**

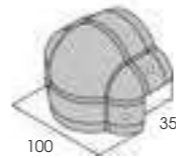

WPTS 150

To install with TS9

Packing **20 pz / box**
Colour **B E**



WPAS 150

To install with TS9

Packing **20 pz / box**
Colour **B E**

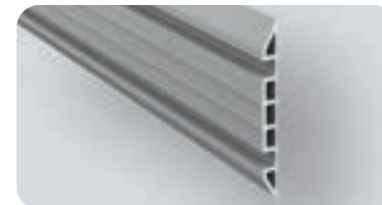
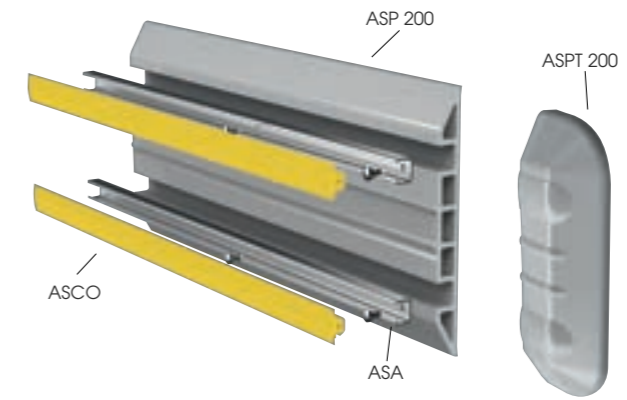

ASP 200



Length **4.000 mm**
Packing **2 pz / box**
Colour **B M**

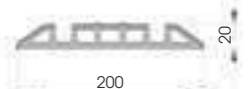

ASPT 200



Packing **10 pz / box**
Colour **B D**

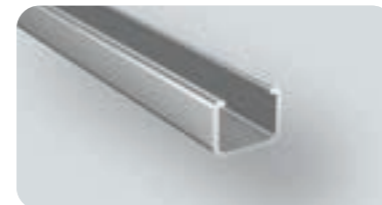
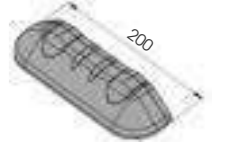

ASA

Material **aluminium**
Length **4.000 mm**
Packing **8 pz / bundle**

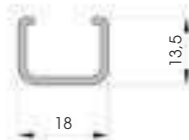

ASCO



Packing **2 pz / box**
L = **32.000 mm**
Colour **A B M D E**

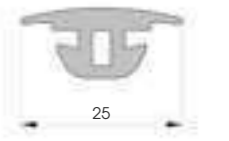



WALL HUG 1000
2000
3000
4000

Length 1000/2000/3000/4000
Packing unpacked
Colour M

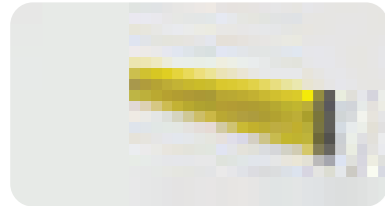
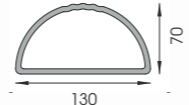

WALL BFLEX 1000
2000
3000
4000

Length 1000/2000/3000/4000
Packing unpacked
Colour M

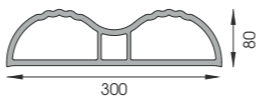

WALL BFLEX MODULAR

Packing unpacked
Colour M

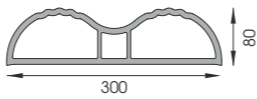

NEWS

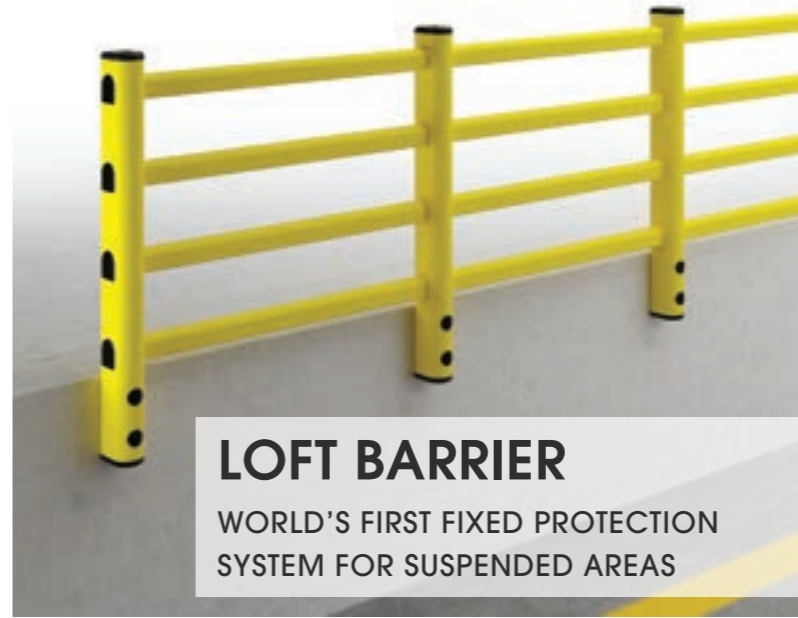

LOFT BARRIER

WORLD'S FIRST FIXED PROTECTION SYSTEM FOR SUSPENDED AREAS

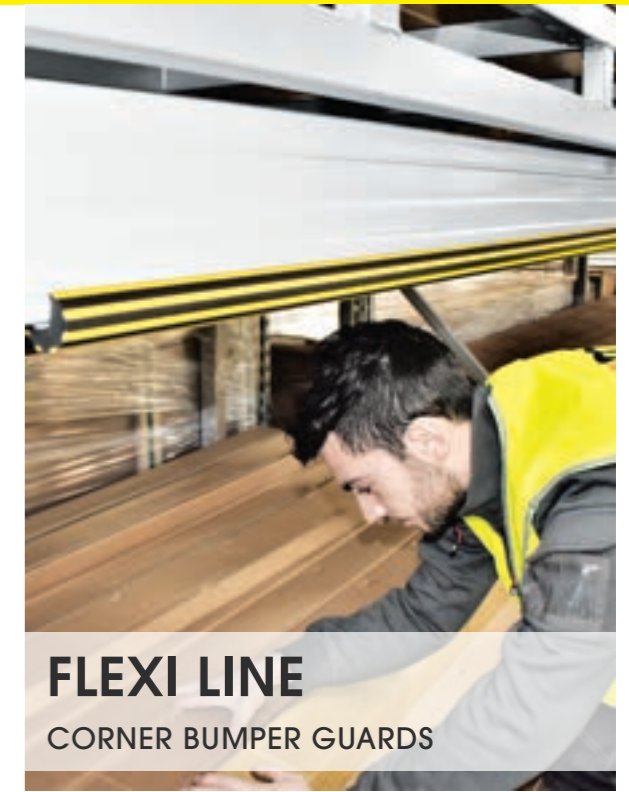

FLEXI LINE

CORNER BUMPER GUARDS



FENCE LINK

STRONG ADAPTABLE SOLUTION FOR RACK-ENDS

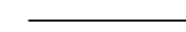
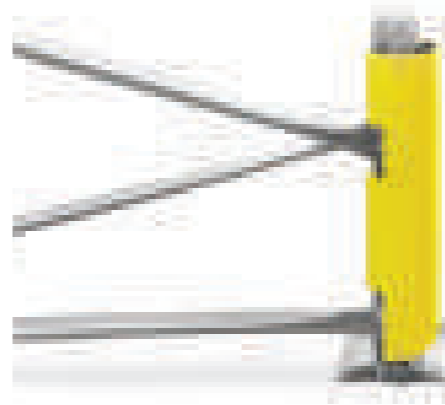

Now available
CUSTOMISED RACK PROTECTOR,
new version of rack protector
processed upon request!

CUSTOMISED RACK PROTECTOR



M12 - M16
HILTI
Hole required Ø 12-16
Galvanized steel.



S12 - S12X150 - S16
HILTI
Hole required Ø 10-10-14
Galvanized steel.



B12 - B16 - B20
HILTI
Hole required Ø 22-28-32
Galvanized steel.



S8FH - S12FH
HILTI
Hole required Ø 6-10
Galvanized steel.
Countersunk.



SF12 - SF16 - SF20 INOX
Hole required Ø 14-18-24
Stainless steel.



M12 - M16 INOX
Hole required Ø 12-16
Stainless steel.



KIT ROD 70-120
HILTI
Hole required Ø 38-56
Galvanized steel.



KIT ROD 70-120 INOX
HILTI
Hole required Ø 38-56
Galvanized steel.



AA12 - AA16
Hole required Ø 22-22
Galvanized steel.
For asphalt.



ASPHALT CHEMICAL
CHEMICAL ANCHOR
385 ML



WIT NORDIC
CHEMICAL ANCHOR
420 ML
(Installation in working cold rooms
with negative temperatures)



FR
HILTI CHEMICAL ANCHOR
300 ML

In collaboration with



MPM srl reserves the right, at any time, to introduce the necessary changes and improvements to its products. Any small imperfection in the products and in the materials used are due to the processing method. Any reproduction of this brochure, even in part, is forbidden.



TM5
Hole required Ø 8.5
Neutral polyethylene. 100/500 Pcs. / bag.



TS9
Hole required Ø 5
White or grey nylon. 1000 Pcs. / bag.



TB14 - TB20
Hole required Ø 4-5
Steel / aluminium (white for Ø 4)
500 Pcs. / box.



TF14 - TF20
Hole required Ø 5-6.5
Aluminium. 500 Pcs. / box.



FIX P90
Galvanized steel and painted.



COVER 90 RE
Galvanized steel and painted.



FIX P90 INOX
Stainless steel.



FIX P150
Galvanized steel and painted.



COVER 150 RE
Galvanized steel and painted.



FIX P150 INOX
Stainless steel.



FIX P150 FH
Galvanized steel and painted.
Countersunk.



FULL FRAME BASE
Galvanized steel and painted.



SHOCK ABSORBER PAD
Soft material, optional for FIXP150.
(To be installed with S12x150)

Colours

A	B	D	E	F	G	H	I	K	L	M	P
RED RAL 3002	GREY RAL 7040	BLACK RAL 9005	WHITE RAL 9010	WHITE RAL 9002	BLUE RAL 5005	GREEN RAL 6029	SILVER RAL 9006	LIGHT GREY RAL 7035	DARK GREY RAL 7024	LIGHT YELLOW RAL 1018	ORANGE

MPM srl reserves the right, at any time, to introduce the necessary changes and improvements to its products. Any small imperfection in the products and in the materials used are due to the processing method. Any reproduction of this brochure, even in part, is forbidden.



SOME OF OUR REFERENCES



THE WORLD'S TOP **LOGISTICS**
PROFESSIONALS CHOOSE OUR
QUALITY MADE IN ITALY



OUR INSTALLATION



OUR INSTALLATION



OUR INSTALLATION

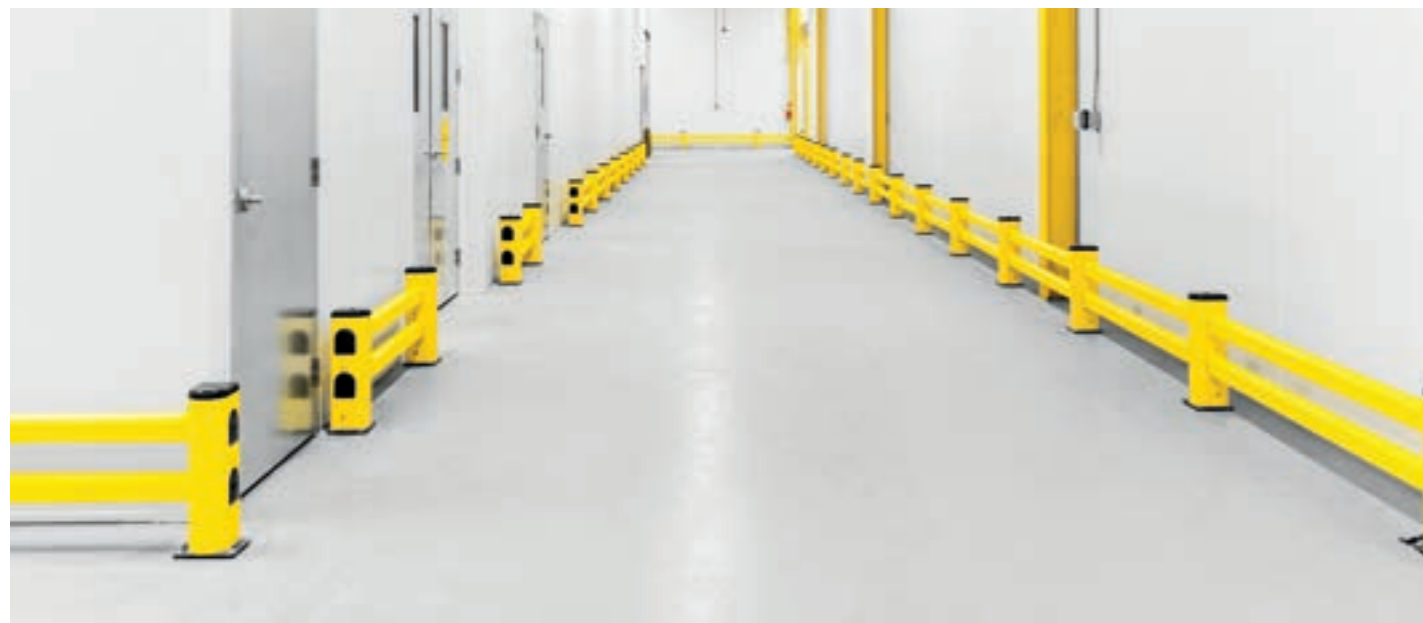

MPM states that:

The safety coefficient and consequent use of the products requires the compliance with the appropriate assembling and installation instructions as defined in the technical catalogue on the corporate website www.mpmprotections.com. Therefore, before buying and installing MPM solutions please consult the technical data sheet of each product in the technical catalogue available on www.mpmprotections.com

Impact resistances indicated in the brochure, or in other documents, refer to laboratory tests and cannot take into account consequences determined by installation methods or peculiarities of the place where the products are installed (in an operational environment vehicle type, speed and mass, routes, angles of impact, ground and anchorage are variable and uncontrolled conditions that no test can replicate); the data refers to an intact product which length is indicated on the test report and it can be affected by alterations from incorrect maintenance, wear and tear, as well as the methods and characteristics of installation (with specific reference to floor-mounted products); the weight, dimensions, colours and characteristics of the material refer to the sample and the conformity with the latter of the product supplied will be subject to normal production tolerance. The product may be affected by environmental installation conditions.

The standard operating temperature of MPM flexible protections is generally from +5 °C to +60 °C. For installations in low temperature environments up to -30 °C an alternative material should be required. The fastness of the colour and its brightness depend on wear and tear and weather conditions that can affect its intensity over time. For outdoor applications exposed to direct sunlight it is possible to choose the grey colour.

Images in the brochure are for advertising purposes only and do not in any way represent how the products should be used.

Full version of MPM products warranty available on corporate website www.mpmprotections.com





MADE IN
ITALY



ALWAYS
DYNAMIC



M.P.M. s.r.l.
Via Europa 2
35010 Fratte
di S. Giustina in Colle
Padova · Italy

T +39 049 9301773
F +39 049 9300427
info@mpmpvc.com
mpmprotections.com

MAY 2022